



SPECIFICATION

Product Model: YX-1024768T104N001B

DESIGNED	CHECKED	Approved
		

Approval by Customer:

Customer name:

Customer model:

Ok

NG, Problem survey

Approved By _____

Revision Record

Table of Contents

List	Description	Page No.
	Cover	1
	Revision Record	2
	Table of Contents	3
1	Scope	4
2	General Information	4
3	External Dimensions	5
4	PIN assignment	6
5	Absolute Maximum Ratings	8
6	DC Characteristics	8
7	LVDS SIGNAL TIMING CHARACTERISTICS	10
8	Backlight Characteristics	14
9	Optical Characteristics	15
10	Reliability Test Conditions and Methods	16
11	Inspection Standard	17
12	Handling Precautions	22
13	Precaution for Use	23
14	Packing Method	23

YuXiang Optoelectronic Co., Ltd.

1. Scope

This specification defines general provisions as well as inspection standards for TFT module supplied by YUXIANG electronics.

If the event of unforeseen problem or unspecified items may occur, naturally shall negotiate and agree to solution

2. General Information

ITEM	STANDARD VALUES	UNITS
LCD type	10.4" TFT	--
Dot arrangement	1024×R.G.B.×768	dots
Color filter array	RGB vertical stripe	--
Display mode	Normally Black	-
Viewing Direction	80/80/80/80	--
Module size	238.6(W)×175.8(H)×5.75(T)	mm
Active area	210.432(W)×157.824(H)	mm
Dot pitch	0.2055(W)×0.2055(H)	mm
Interface	LVDS 6/8 bit	--
Operating temperature	-30 ~ +80	°C
Storage temperature	-30 ~ +80	°C
Weight	TBD	g

YuXiang Optoelectronic Co., Ltd.

4.PIN assignment

4.1 TFT Interface Description

PIN	PIN NAME	DESCRIPTION	Remark
1	NC	Reserved as BIST function for INX test	Note 1
2	GND	Ground	
3	RIN 3+	Positive LVDS differential data input (+)	
4	RIN 3-	Negative LVDS differential data input (-)	
5	GND	Ground	
6	CLK+	Positive LVDS differential data input (+)	
7	CLK-	Negative LVDS differential data input (-)	
8	GND	Ground	
9	RIN 2+	Positive LVDS differential data input (+)	
10	RIN 2-	Negative LVDS differential data input (-)	
11	GND	Ground	
12	RIN 1+	Positive LVDS differential data input (+)	
13	RIN 1-	Negative LVDS differential data input (-)	
14	GND	Ground	
15	RIN0 +	Positive LVDS differential data input (+)	
16	RIN0 -	Negative LVDS differential data input (-)	
17	GND	Ground	
18	NC	No connection	
19	GND	Ground	
20	SEL6/8	Selection for 6 bits/8bit LVDS data input Low or NC : 8 bit input mode High : 6 bit input mode	Note 2
21	NC	Reversed as EE_WP for OTP function	Note 3
22	NC	Reversed as EE_SDA for OTP function	Note 3
23	NC	Reversed as EE_SCL for OTP function	Note 3
24	REVERSE	Reverse panel function (Display rotation)	Note 4
25-27	GND	Ground	
28-30	VDD	Power supply: + 3.3V	

Connector:Input LVDS CONN,30pins, P-two , 187098-30091

Note:

YuXiang Optoelectronic Co., Ltd.

1. Pin1 is reversed as BIST function for test, don't connect signal to this pin, keep floating.
2. SEL6/8 is used for selecting 6bit/8bit LVDS data input, L or NC: 8bit; High:6bit.
3. Pin21,22,23 are used as SPI interface for OTP function, don't connect any signal to these pin, and don't short them, keep floating.
4. Reverse pin is used for selecting scanning direction.

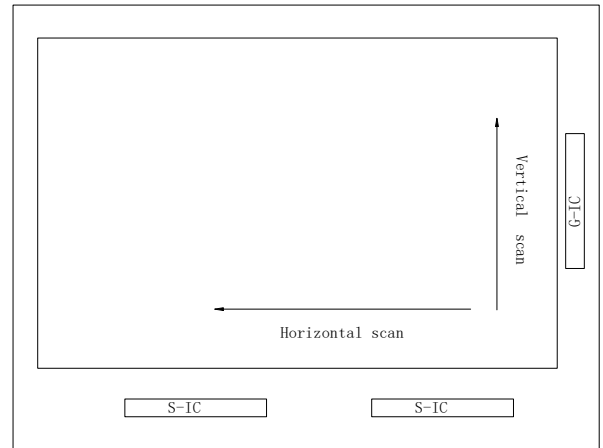
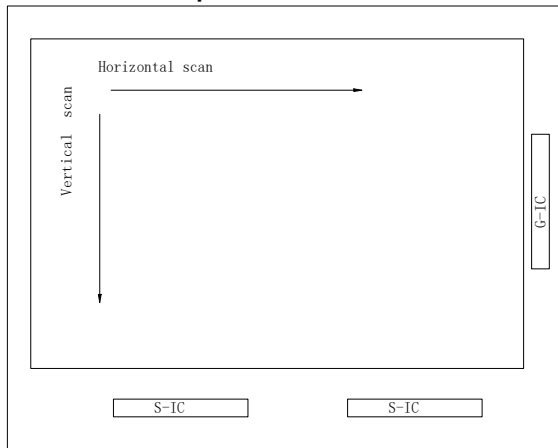

Fig. 1 Normal scan (Pin24, Reverse = Low or NC) Fig. 2 Reverse scan (Pin24, Reverse = High)

4.2 BL converter power IC Description

PIN	PIN NAME	DESCRIPTION
1	LED_VCCS	12V input
2	LED_VCCS	12V input
3	GND	Ground
4	LED_PWM	PWM
5	LED_EN	Converter power IC Enable (Active High)

Connector:Input BL power CONN,5pins, Cillux,CI4205M2HRD-NH

4.3 BL Description

PIN	PIN NAME	DESCRIPTION
1	LED+	Red wire
2	LED1-	White wire
3	LED2-	White wire

Connector:Output BL power CONN, 3pins, Cillux,CI4203M2HRD-NH

YuXiang Optoelectronic Co., Ltd.

5. Absolute Maximum Ratings

Item	Symbol	Min.	Max.	Unit	Remark
Digital Supply Voltage	VDD	-0.3	4.0	V	
VIN Voltage	VLED	-0.3	50	V	
Operating Temperature	TOP	-30	80	°C	
Storage Temperature	TST	-30	80	°C	

6. DC Characteristics

6.1 Parameter

Item	Symbol	Values			Unit	Remark
		Min.	Typ.	Max.		
Power voltage	VDD	3.0	3.3	3.6	V	
	LED_VCCS	11	12	13	V	
Input logic high voltage	V _{IH}	0.7VDD	-	VDD	V	1
Input logic low voltage	V _{IL}	0	-	0.3VDD	V	
Current for Power	I _{VDD}		385	424	mA	VDD =3.3V@frame 60 Hz, White pattern
	I _{LED_VCCS}	-	0.52	-	A	100% PWM Duty @ VLED+ =33V, ILED=80mA*2
LED_EN Control Level	BL On	3.0	-	5	V	
	BL Off	0	-	0.3	V	
LED_PWM Control Level	PWM High Level	3.0	-	5	V	
	PWM Low Level	0	-	0.3	V	
LED_PWM Control Frequency	f _{PWM}	1K	-	20K	Hz	2

YuXiang Optoelectronic Co., Ltd.

Item	Symbol	Min.	Typ.	Max.	Unit	Remark
Digital Supply Voltage	VDD	2.75	3.3	3.6	V	
VIN Voltage	LED_VCCS	-0.3	-	25	V	
Input logic high voltage	V _{IH}	0.7*VDD	-	VDD	V	
Input logic low voltage	V _{IL}	GND	-	0.3*VDD	V	

Note 1: Including signal: SEL6/8 & Reverse

Note 2: LED_PWM duty >10%.

6.2 BL power output

Item	Symbol	Values			Unit	Remark
		Min.	Typ.	Max.		
Voltage for LED backlight	V _{led}	30.8	33	38.5	V	1
Current for LED backlight	I _{led}		160		mA	2

Note 1: output power LED+ OVP is 40V.

Note 2: Set BL feedback 2 channels, each channel feedback current is 80mA

6.3 Power sequence

The power sequence specifications are shown as the following table and diagram.

YuXiang Optoelectronic Co., Ltd.

Symbol	Value		Unit
	Min.	Max.	
t_1	1	20	ms
t_2	1	5	ms
t_3	10	50	ms
t_4	200	500	ms
t_5	200	500	ms
t_6	50	200	ms
t_7	0	20	ms
t_8	500	-	ms
t_A	0	50	ms
t_B	0	50	ms

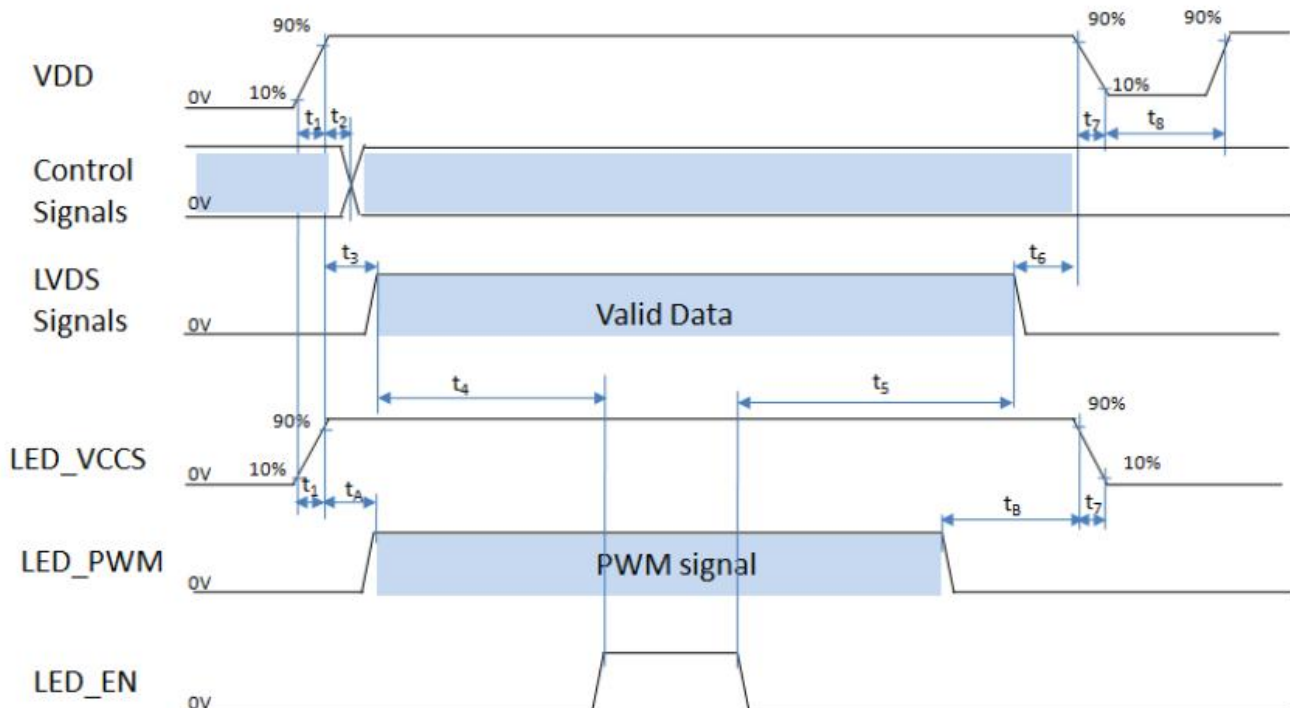

Note 1: Please don't plug the interface cable of on when system is turned on.

Note 2: Please avoid floating state of the interface signal during signal invalid period.

Note 3: It is recommended that the backlight power must be turned on after the power supply for LCD and the interface signal is valid.

Note 4: Control signals include SEL6/8 & Reverse.

YuXiang Optoelectronic Co., Ltd.

7. LVDS SIGNAL TIMING CHARACTERISTICS

7.1AC Electrical characteristics

Parameter	Symbol	Min	Typ	Max	Unit	Condition
Clock frequency	RxFCLK	26.2	51.2	71	MHz	
Input data skew margin	TRSKM	500	500	$1/(2 \times \text{RxFCLK})$	ps	Typical value for 1024*600 resolution
Clock high time	TLVCH		$4/(7 \times \text{RxFCLK})$		ns	VID =400mv RxVCM=1.2V RxFCLK=71MHz VDD_LVDS=3.3V
Clock low time	TLVCL		$3/(7 \times \text{RxFCLK})$		ns	
VSD setup time	TenPLL	0	TenPLL	150	us	

7.2 Input clock and data timing diagram

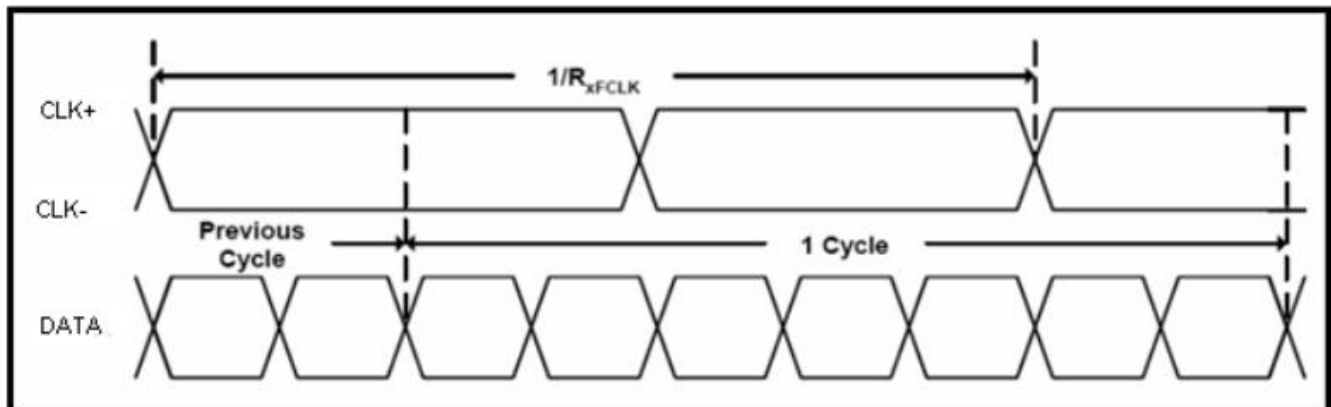

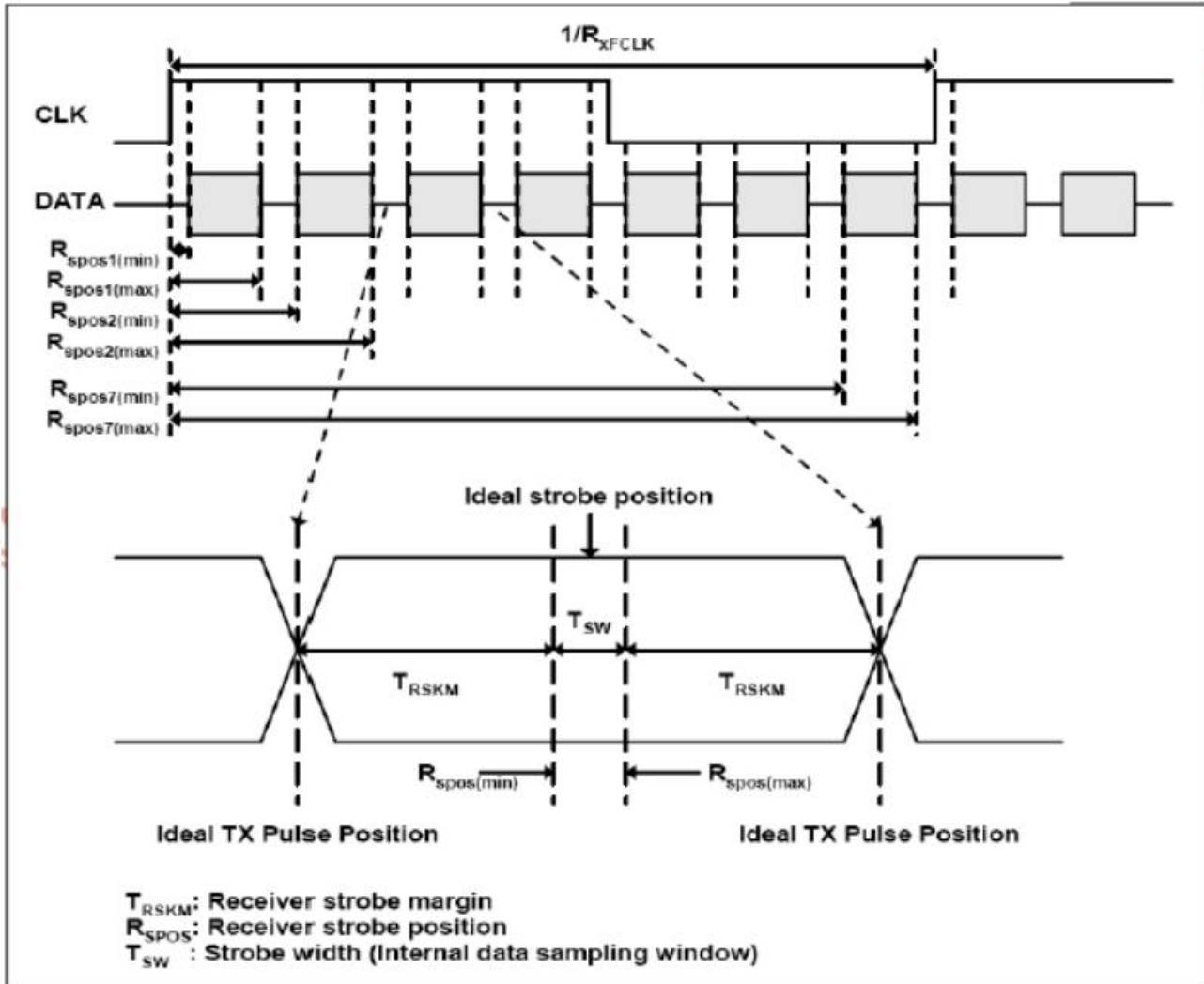

7.3 DC electrical characteristics

Parameter	Symbol	Values			Unit	Remark
		Min.	Typ.	Max.		
LVDS Differential input high Threshold voltage	R_{xVTH}	-	-	+100	mV	$R_{xVCM}=1.2V$
LVDS Differential input low Threshold voltage	R_{xVTL}	-100	-	-	mV	
Input Voltage range (Singled-end)	R_{xVIN}	0	-	$V_{DD}-1.2+$ $ V_{ID} /2$	V	
LVDS Differential input common mode voltage	R_{xVCM}	$ V_{ID} /2$	-	$V_{DD}-1.2$	V	
LVDS Differential voltage	$ V_{ID} $	0.2	-	0.6	V	

YuXiang Optoelectronic Co., Ltd.

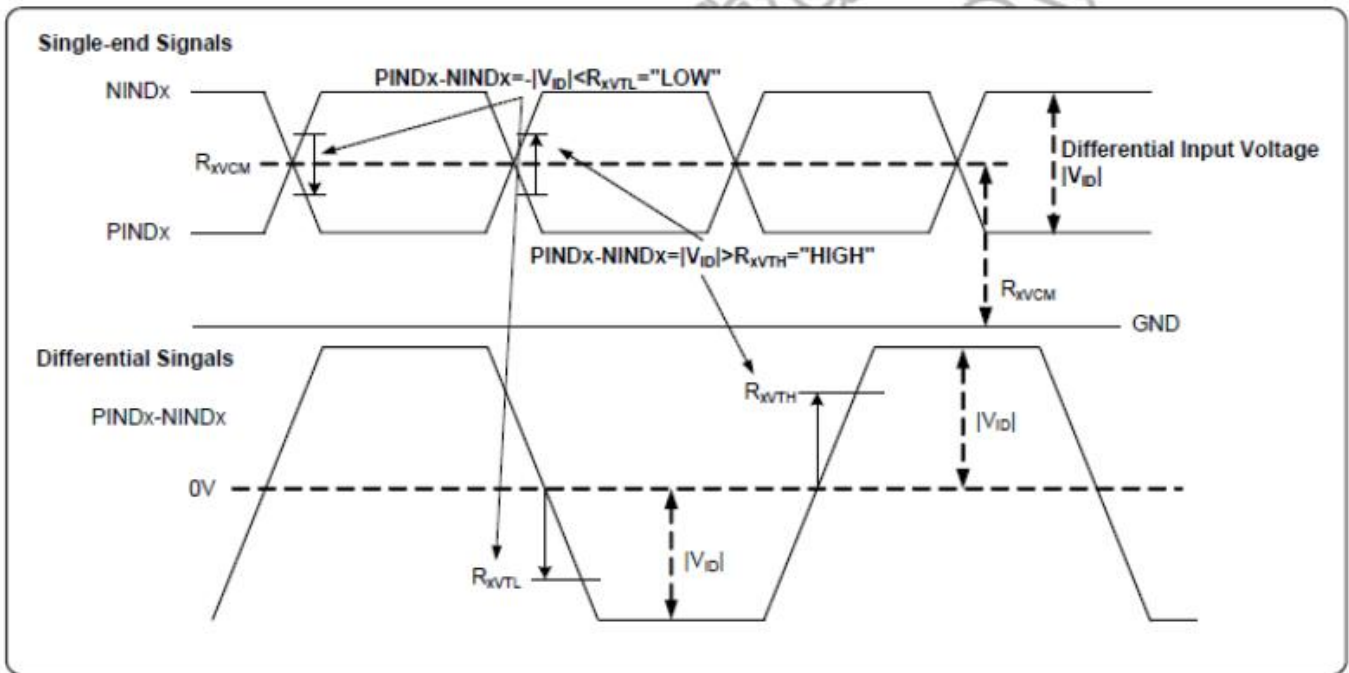

7.4 data timing

Parameter	Symbol	Spec.			Unit
		Min.	Typ.	Max.	
DCLK frequency	fclk	52	65	71	MHz
Horizontal display area	thd	1024			DCLK
HSD period	th	1114	1344	1400	DCLK
HSD blanking	thb+thfp	90	320	376	DCLK
Vertical display area	tvd	768			T_H
VSD period	tv	778	806	845	T_H
VSD blanking	tvbp+tvfp	10	38	77	T_H

7.5 LVDS data input format

SEL6/8 = "High" for 6 bits LVDS Input

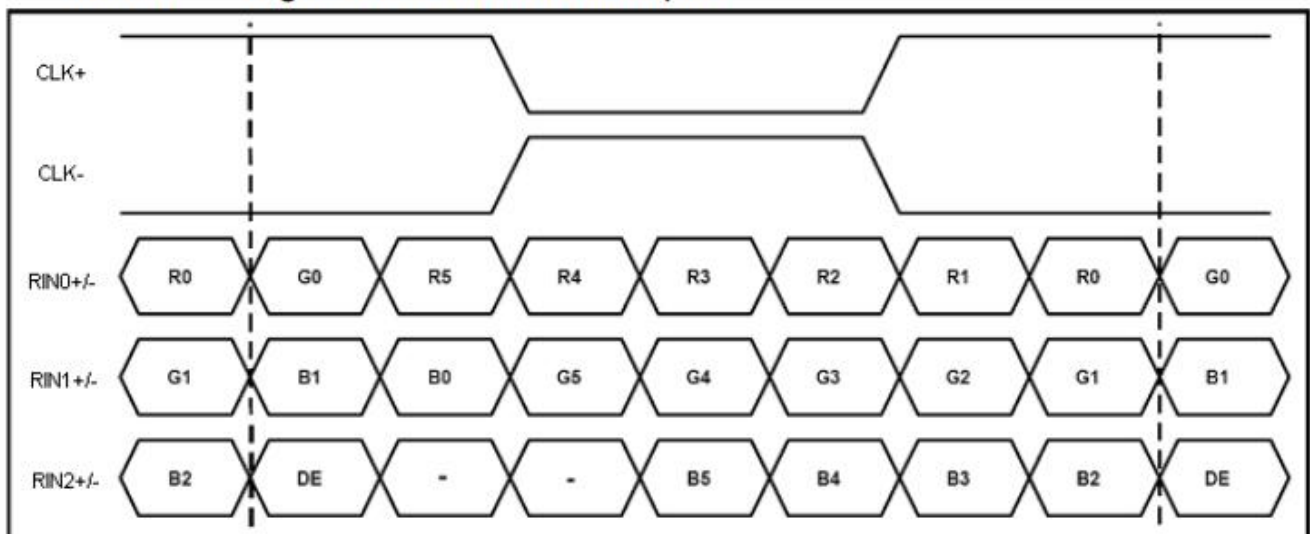

SEL6/8 = "Low" or "NC" for 8 bits LVDS Input

YuXiang Optoelectronic Co., Ltd.

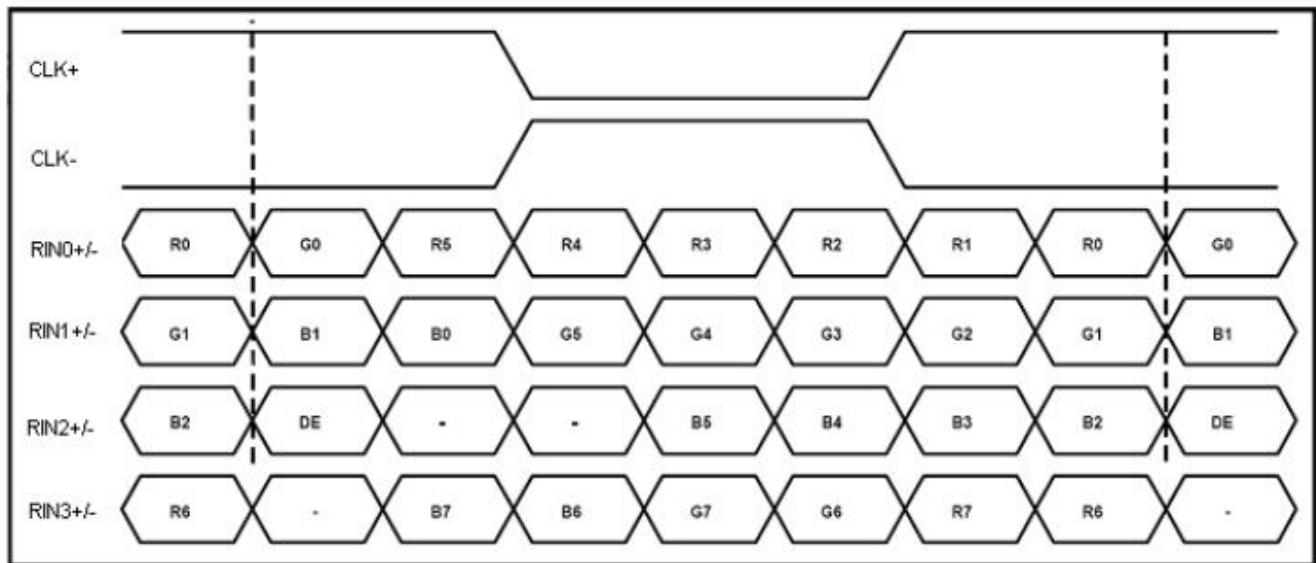

8. Backlight Characteristic

Item	Symbol	MIN	TYP	MAX	UNIT	NOTE
Backlight Power	LED_VCCS	-0.3	12	25	V	Ta = 25°C
Backlight Power	ILED_VCCS	-	0.5	0.8	A	LED_VCCS=12V
EN Signal Voltage	VIH	3.0		5.0	V	
	VIL	GND		0.3	V	
Luminous Intensity for LCM	VIH	3.0		5.0	V	
	VIL	GND		0.3	V	
PWM Frequency	LED_PWM	1K	-	20K	Hz	
Lifetime		50000	-	-	Hr	
Color	White					
Average Brightness	-	800	1000	-	Cd/cm2	
Luminance uniformity	-	75	-	-	%	

YuXiang Optoelectronic Co., Ltd.

9. Optical Characteristics

Item	Conditions	Min.	Typ.	Max.	Unit	Note	
Viewing Angle (CR>10)	Horizontal	θ_L	80	-	-	degree	(1)
		θ_R	80	-	-		
	Vertical	θ_T	80	-	-		
		θ_B	80	-	-		
Contrast Ratio	Center	700	1000	-	-	(2)	
Response Time	Rising	-	14	19	ms	(3)	
	Falling		11	16	ms		
CF Color Chromaticity (CIE1931)	Red x	TYP. -0.05	0.651	TYP. +0.05	-	(4)	
	Red y		0.345		-		
	Green x		0.315		-		
	Green y		0.611		-		
	Blue x		0.145		-		
	Blue y		0.093		-		
	White x		0.326		-		
	White y		0.383		-		

Note (1) Definition of Viewing Angle (θ_x , θ_y):
Viewing angles are measured by BM5A

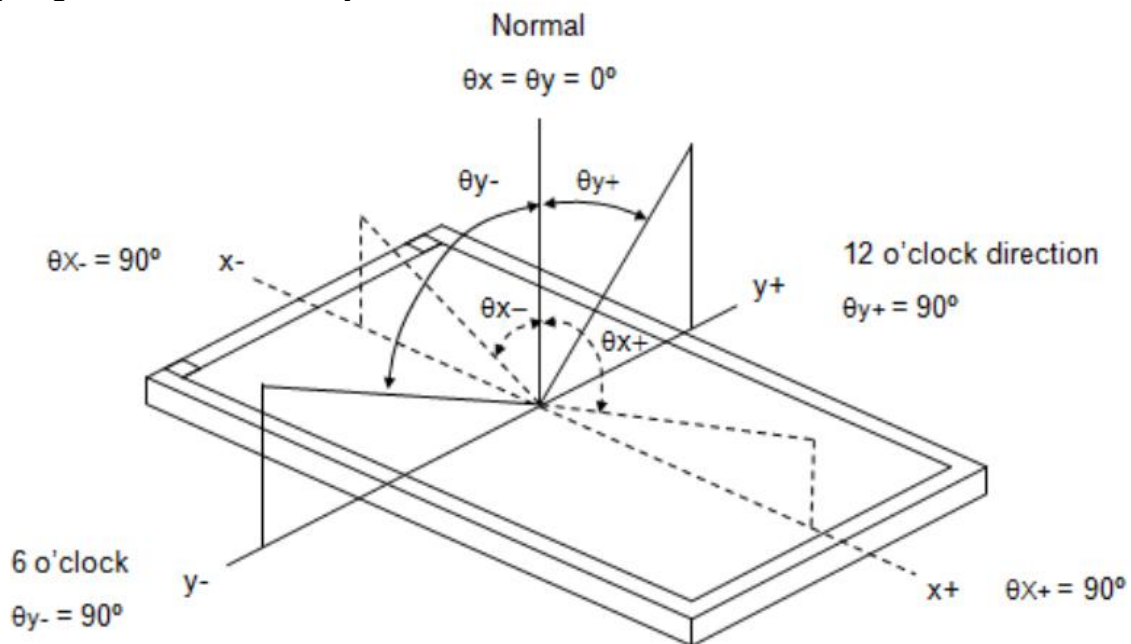

Note (2) Definition of Contrast Ratio (CR):

YuXiang Optoelectronic Co., Ltd.

The contrast ratio can be calculated by the following expression.

$$\text{Contrast Ratio (CR)} = L_{255} / L_0$$

L255: Luminance of gray level 255

L 0: Luminance of gray level 0

CR = CR (5), where CR (X) is corresponding to the Contrast Ratio of the point X at the figure in

Note (3) Definition of Response Time (TR, TF):

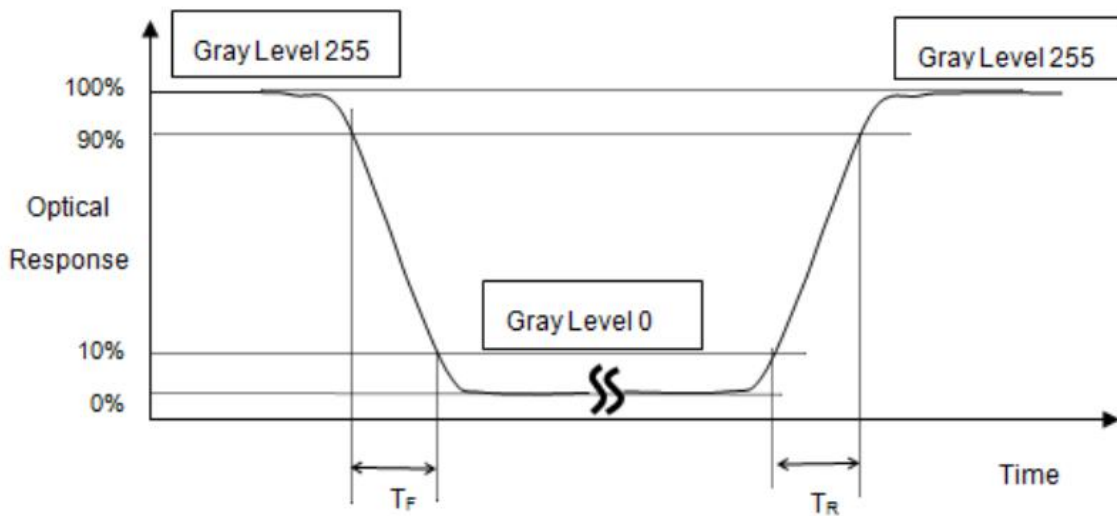

Note (4) Measurement Setup:

The LCD assembly should be stabilized at given temperature for 30 minutes to avoid abrupt temperature change during measuring. In order to stabilize the luminance, the measurement should be executed after lighting Backlight for 30 minutes in a windless room.

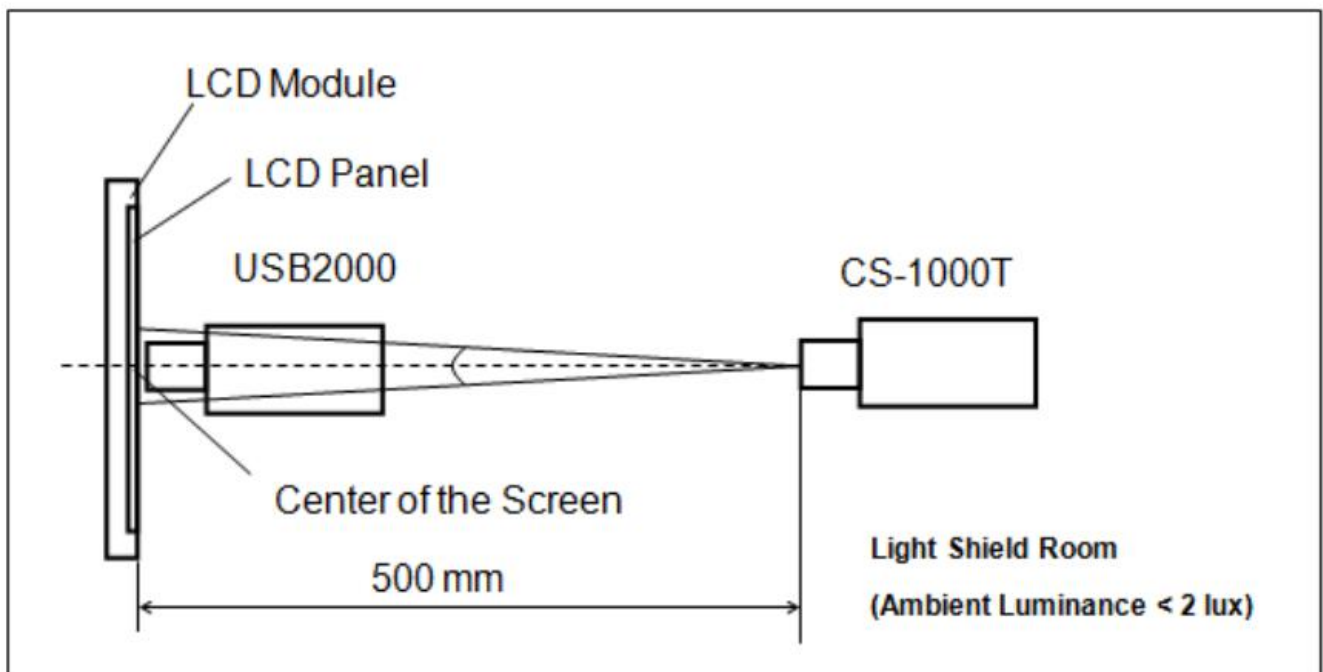

YuXiang Optoelectronic Co., Ltd.

10. Reliability Test Conditions and Methods

NO.	TEST ITEMS	TEST CONDITION	
①	High Temperature Storage	Keep in 80°C 96 hrs Surrounding temperature, then storage at normal condition 4hrs.	
②	Low Temperature Storage	Keep in -30°C ±5°C 96 hrs Surrounding temperature, then storage at normal condition 4hrs.	
③	High Temperature Operating Test	80°C*96Hrs	
④	Low Temperature Operating Test	-30°C*96Hrs	
⑤	High Temperature / High Humidity Operating Test	60 °C / 90% R.H , 96 hrs.	
⑥	High Temperature / High Humidity Storage Test	Keep in 60 °C / 90% R.H duration for 96 hrs Surrounding temperature, then storage at normal condition 4hrs.	
⑦	Temperature Cycling Storage Test	$ \begin{array}{ccccccc} & -30^{\circ}\text{C} & \rightarrow & +25^{\circ}\text{C} & \rightarrow & 80^{\circ}\text{C} & \rightarrow & +25^{\circ}\text{C} \\ & (30\text{mins}) & & (5\text{mins}) & & (30\text{mins}) & & (5\text{mins}) \\ & & & \longleftarrow & & \longrightarrow & & \\ & & & & & 30 \text{ Cycle} & & \end{array} $ Surrounding temperature, then storage at normal condition 4hrs.	
⑧	ESD Test	Air Discharge: Apply 6 KV with 5 times Discharge for each polarity +/-	Contact Discharge: Apply 250 V with 5 times discharge for each polarity +/-
		1. Temperature ambience : 15°C ~ 35°C 2. Humidity relative : 30% ~ 60% 3. Energy Storage Capacitance(Cs + Cd) : 150pF±10% 4. Discharge Resistance(Rd) : 330Ω±10% 5. Discharge, mode of operation : Single Discharge (time between successive discharges at least 1 sec) (Tolerance if the output voltage indication : ±5%)	
⑨	Vibration Test (Packaged)	1. Sine wave 10 ~ 55 Hz frequency (1 min/sweep) 2. The amplitude of vibration :1.5 mm 3. Each direction (X、Y、Z) duration for 2 Hrs	

YuXiang Optoelectronic Co., Ltd.

⑩	Drop Test (Packaged)	Drop	Packing Weight (Kg)	Drop Height (cm)
			0 ~ 45	122
			4	
			45.4 ~ 90.8	76
			90.8 ~ 454	61
			Over 454	46
Direction : ※ 1 corner / 3 edges / 6 sides each 1time				

11. Inspection Standard

11.1. QUALITY :

THE QUALITY OF GOODS SUPPLIED TO PURCHASER SHALL COME UP TO THE FOLLOWING STANDARD.

11.1.1. THE METHOD OF PRESERVING GOODS

AFTER DELIVERY OF GOODS FROM AMSON TO PURCHASER. PURCHASER SHALL CONTROL THE LCM AT -10 TO 40 ,AND IT MIGHT BE DESIRABLE TO KEEP AT THE NORMAL ROOM TEMPERATURE AND HUMIDITY UNTIL INCOMING INSPECTION OR THROWING INTO PROCESS LINE.

11.1.2. INCOMING INSPECTION

(A) THE METHOD OF INSPECTION

IF PURCHASER MAKE AN INCOMING INSPECTION , A SAMPLING PLAN SHALL BE APPLIED ON THE CONDITION THAT QUALITY OF ONE DELIVERY SHALL BE REGARDED AS ONE LOT.

(B) THE STANDARD OF QUALITY

ISO-2859-1 (SAME AS MIL-STD-105E) ,LEVEL:II

CLASS	AQL(%)
CRITICAL	0.4 %
MAJOR	0.65 %
MINOR	1.5 %

EVERY ITEM SHALL BE INSPECTED ACCORDING TO THE CLASS.

(C) MEASURE

IF AS THE RESULT OF ABOVE RECEIVING INSPECTION , A LOT OUT IS DISCOVERED. PURCHASER SHALL BE INFORM SELLER OF IT WITHIN SEVEN DAYS. BUT FIRST SHIPMENT WITHIN FOURTEEN DAYS.

11.1.3. WARRANTY POLICY

AMSON WILL PROVIDE ONE-YEAR WARRANTY FOR THE PRODUCTS ONLY IF UNDER SPECIFICATION OPERATING CONDITIONS. AMSON WILL REPLACE NEW PRODUCTS FOR THESE DEFECT PRODUCTS WHICH UNDER WARRANTY PERIOD AND BELONG TO THE RESPONSIBILITY OF AMSON.

11.2. CHECKING CONDITION

11.2.1.CHECKING DIRECTION SHALL BE IN THE 45 DEGREE AREA TO FACE THE SAMPLE.

11.2.2.CHECKER SHALL SEE OVER 300±25 mm. WITH BARE EYES FAR FROM SAMPLE

Ambient Illumination:

Functional detection in 600nits backlight environment

Appearance detection in 800~1000 Lux external environment

YuXiang Optoelectronic Co., Ltd.

11.3. INSPECTION PLAN :

CLASS	ITEM	JUDGEMENT	CLASS
PACKING & INDICATE	1. OUTSIDE AND INSIDE PACKAGE	"MODEL NO." , "LOT NO." AND "QUANTITY" SHOULD INDICATE ON THE PACKAGE.	Minor
	2. MODEL MIXED AND QUANTITY	OTHER MODEL MIXED.....REJECTED QUANTITY SHORT OR OVER.....REJECTED	Critical
	3. PRODUCT INDICATION	"MODEL NO." SHOULD INDICATE ON THE PRODUCT	Major
ASSEMBLY	4. DIMENSION, LCD GLASS SCRATCH AND SCRIBE DEFECT.	ACCORDING TO SPECIFICATION OR DRAWING.	Major
APPEARANCE	5. VIEWING AREA	POLARIZER EDGE OR LCD'S SEALING LINE IS VISABLE IN THE VIEWING AREAREJECTED	Minor
	6. BLEMISH · BLACK SPOT · WHITE SPOT IN THE LCD AND LCD GLASS CRACKS	ACCORDING TO STANDARD OF VISUAL INSPECTION(INSIDE VIEWING AREA)	Minor
	7. BLEMISH · BLACK SPOT WHITE SPOT AND SCRATCH ON THE POLARIZER	ACCORDING TO STANDARD OF VISUAL INSPECTION(INSIDE VIEWING AREA)	Minor
	8. BUBBLE IN POLARIZER	ACCORDING TO STANDARD OF VISUAL INSPECTION(INSIDE VIEWING AREA)	Minor
	9. LCD'S RAINBOW COLOR	STRONG DEVIATION COLOR (OR NEWTON RING) OF LCD.....REJECTED. OR ACCORDING TO LIMITED SAMPLE (IF NEEDED, AND INSIDE VIEWING AREA)	Minor
ELECTRICAL	10. ELECTRICAL AND OPTICAL CHARACTERISTICS (CONTRAST · VOP · CHROMATICITY ... ETC)	ACCORDING TO SPECIFICATION OR DRAWING . (INSIDE VIEWING AREA)	Critical
	11.MISSING LINE	MISSING DOT · LINE · CHARACTERREJECTED	Critical
	12.SHORT CIRCUIT· WRONG PATTERN DISPLAY	NO DISPLAY · WRONG PATTERN DISPLAY · CURRENT CONSUMPTION OUT OF SPECIFICATION..... REJECTED	Critical
	13. DOT DEFECT (FOR COLOR AND TFT)	ACCORDING TO STANDARD OF VISUAL INSPECTION	Minor

YuXiang Optoelectronic Co., Ltd.

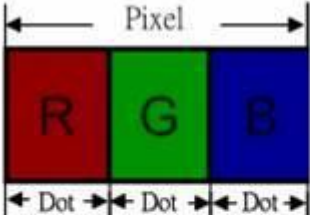
NO.	CLASS	ITEM	JUDGEMENT																				
11.4.1	MINOR	BLACK AND WHITE SPOT FOREIGN MATERIEL DUST IN THE CELL BLEMISH SCRATCH	<p>(A) ROUND TYPE: unit : mm.</p> <table border="1"> <thead> <tr> <th>DIAMETER (mm.)</th> <th>ACCEPTABLE Q'TY</th> </tr> </thead> <tbody> <tr> <td>$\Phi \leq 0.15$</td> <td>Distance>1mm</td> </tr> <tr> <td>$0.15 < \Phi \leq 0.4$</td> <td>3 (Distance>15mm)</td> </tr> <tr> <td>$0.4 < \Phi$</td> <td>0</td> </tr> </tbody> </table> <p>NOTE: $\Phi=(\text{LENGTH}+\text{WIDTH})/2$</p> <p>(B) LINEAR TYPE: unit : mm.</p> <table border="1"> <thead> <tr> <th>LENGTH</th> <th>WIDTH</th> <th>ACCEPTABLE Q'TY</th> </tr> </thead> <tbody> <tr> <td>-----</td> <td>$W \leq 0.03$</td> <td>Distance>1mm</td> </tr> <tr> <td>$L \leq 4.0$</td> <td>$0.03 < W \leq 0.05$</td> <td>3 (Distance>15mm)</td> </tr> <tr> <td>-----</td> <td>$0.05 < W$</td> <td>FOLLOW ROUND TYPE</td> </tr> </tbody> </table>	DIAMETER (mm.)	ACCEPTABLE Q'TY	$\Phi \leq 0.15$	Distance>1mm	$0.15 < \Phi \leq 0.4$	3 (Distance>15mm)	$0.4 < \Phi$	0	LENGTH	WIDTH	ACCEPTABLE Q'TY	-----	$W \leq 0.03$	Distance>1mm	$L \leq 4.0$	$0.03 < W \leq 0.05$	3 (Distance>15mm)	-----	$0.05 < W$	FOLLOW ROUND TYPE
DIAMETER (mm.)	ACCEPTABLE Q'TY																						
$\Phi \leq 0.15$	Distance>1mm																						
$0.15 < \Phi \leq 0.4$	3 (Distance>15mm)																						
$0.4 < \Phi$	0																						
LENGTH	WIDTH	ACCEPTABLE Q'TY																					
-----	$W \leq 0.03$	Distance>1mm																					
$L \leq 4.0$	$0.03 < W \leq 0.05$	3 (Distance>15mm)																					
-----	$0.05 < W$	FOLLOW ROUND TYPE																					
11.4.2	MINOR	BUBBLE IN POLARIZER DENT ON POLARIZER	<p style="text-align: right;">unit : mm.</p> <table border="1"> <thead> <tr> <th>DIAMETER</th> <th>ACCEPTABLE Q'TY</th> </tr> </thead> <tbody> <tr> <td>$\Phi \leq 0.2$</td> <td>Distance>1mm</td> </tr> <tr> <td>$0.2 < \Phi \leq 0.5$</td> <td>3 (Distance>15mm)</td> </tr> <tr> <td>$0.5 < \Phi$</td> <td>0</td> </tr> </tbody> </table>	DIAMETER	ACCEPTABLE Q'TY	$\Phi \leq 0.2$	Distance>1mm	$0.2 < \Phi \leq 0.5$	3 (Distance>15mm)	$0.5 < \Phi$	0												
DIAMETER	ACCEPTABLE Q'TY																						
$\Phi \leq 0.2$	Distance>1mm																						
$0.2 < \Phi \leq 0.5$	3 (Distance>15mm)																						
$0.5 < \Phi$	0																						
11.4.3	MINOR	Dot Defect	<table border="1"> <thead> <tr> <th>Items</th> <th>ACC. Q'TY</th> </tr> </thead> <tbody> <tr> <td>Bright dot</td> <td>$N \leq 2$ (Distance>15mm)</td> </tr> <tr> <td>Dark dot</td> <td>$N \leq 3$ (Distance>15mm)</td> </tr> </tbody> </table> <p>Pixel Define :</p>  <p>Note 1: The definition of dot: The size of a defective dot over 1/2 of whole dot is regarded as one defective dot. Definition:<1/2dot and visible by 5% ND filter $N \leq 5$</p> <p>Note 2: Bright dot: Dots appear bright and unchanged in size in which LCD panel is displaying under black pattern.</p> <p>Note 3: Dark dot: Dots appear dark and unchanged in size in which LCD panel is displaying under pure red, green ,blue pattern.</p>	Items	ACC. Q'TY	Bright dot	$N \leq 2$ (Distance>15mm)	Dark dot	$N \leq 3$ (Distance>15mm)														
Items	ACC. Q'TY																						
Bright dot	$N \leq 2$ (Distance>15mm)																						
Dark dot	$N \leq 3$ (Distance>15mm)																						
11.4.4	MINOR	Mura	Not visible through 5% ND filter in 50% gray or judge by limit sample if necessary																				

YuXiang Optoelectronic Co., Ltd.

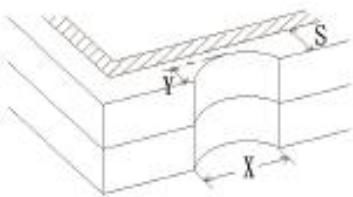
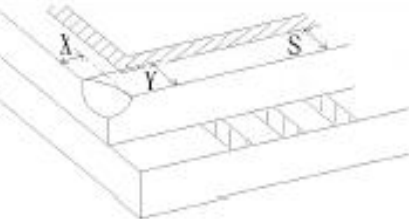
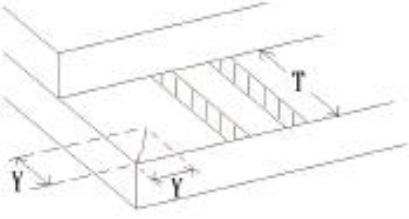
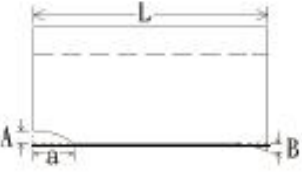
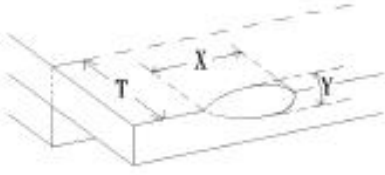
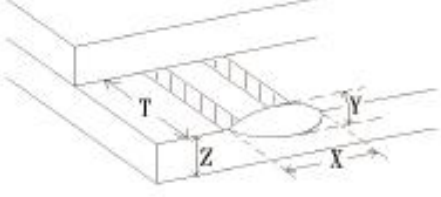
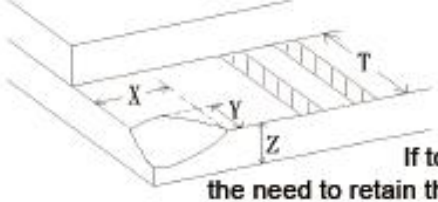
NO.	CLASS	ITEM	JUDGEMENT
11.4.5	MINOR	LCD GLASS CHIPPING	 $X \geq 3\text{mm}$ $Y > S$ <p>Reject</p>
11.4.6	MINOR	LCD GLASS CHIPPING	 $X \text{ or } Y > S$ <p>Reject</p>
11.4.7	MAJOR	LCD GLASS GLASS CRACK	 <p>Continuous burst NG</p> <p>Reject</p>
11.4.8	MAJOR	LCD GLASS SCRIBE DEFECT	 <p>ACCORDING TO DIMENSION</p>
11.4.9	MINOR	LCD GLASS CHIPPING (ON THE TERMINAL AREA)	 $Y < 1/2Z$ $Y \geq 0.5\text{mm}$ $X \geq 3\text{mm}$ <p>Reject</p>
11.4.10	MINOR	LCD GLASS CHIPPING (ON THE TERMINAL SURFACE)	 $Y < 1/2Z$ $Y \geq 0.5\text{mm}$ $X \geq 3\text{mm}$ <p>Reject</p>
11.4.11	MINOR	LCD GLASS CHIPPING	 $X \geq 3\text{mm}$ $Y \geq T$ <p>Reject</p> <p>If touch the electrode lines, the need to retain the two-thirds electrode lines</p>

YuXiang Optoelectronic Co., Ltd.

12. Handling Precautions

12.1 Mounting method

The LCD panel of YUXIANG TFT module consists of two thin glass plates with polarizes which easily be damaged. And since the module is so constructed as to be fixed by utilizing fitting holes in the printed circuit board.

Extreme care should be needed when handling the LCD modules.

12.2 Caution of LCD handling and cleaning

When cleaning the display surface, Use soft cloth with solvent [Recommended below] and wipe lightly

- Isopropyl alcohol
- Ethyl alcohol

Do not wipe the display surface with dry or hard materials that will damage the polarizer surface.

Do not use the following solvent:

- Water
- Aromatics

Do not wipe ITO pad area with the dry or hard materials that will damage the ITO patterns

Do not use the following solvent on the pad or prevent it from being contaminated:

- Soldering flux
- Chlorine (Cl) , Sulfur (S)

If goods were sent without being silicon coated on the pad, ITO patterns could be damaged due to the corrosion as time goes on.

If ITO corrosion happens by miss-handling or using some materials such as Chlorine (Cl), Sulfur (S) from customer, Responsibility is on customer.

12.3 Caution against static charge

The LCD module uses C-MOS LSI drivers, so we recommend that you:

Connect any unused input terminal to Power or Ground, do not input any signals before power is turned on, and ground your body, work/assembly areas, and assembly equipment to protect against static electricity.

12.4 packing

- Module employs LCD elements and must be treated as such.
- Avoid intense shock and falls from a height.
- To prevent modules from degradation, do not operate or store them exposed direct to sunshine or high temperature/humidity

12.5 Caution for operation

- It is an indispensable condition to drive LCD's within the specified voltage limit since the higher voltage than the limit causes the shorter LCD life.
- An electrochemical reaction due to direct current causes LCD's undesirable deterioration, so that the use of direct current drive should be avoided.
- Response time will be extremely delayed at lower temperature than the operating temperature range and on the other hand at higher temperature LCD's show dark color in them. However those phenomena do not mean malfunction or out of order with LCD's, which will come back in the specified operation temperature.
- If the display area is pushed hard during operation, some font will be abnormally displayed but it resumes normal condition after turning off once.
- Slight dew depositing on terminals is a cause for electro-chemical reaction resulting in terminal open circuit.

Usage under the maximum operating temperature, 50%Rh or less is required.

YuXiang Optoelectronic Co., Ltd.

12.6 storing

In the case of storing for a long period of time for instance, for years for the purpose or replacement use, the following ways are recommended.

- Storage in a polyethylene bag with the opening sealed so as not to enter fresh air outside in it. And with no desiccant.
- Placing in a dark place where neither exposure to direct sunlight nor light's keeping the storage temperature range.
- Storing with no touch on polarizer surface by the anything else.
[It is recommended to store them as they have been contained in the inner container at the time of delivery from us

12.7 Safety

- It is recommendable to crash damaged or unnecessary LCD's into pieces and wash off liquid crystal by either of solvents such as acetone and ethanol, which should be burned up later.
- When any liquid leaked out of a damaged glass cell comes in contact with your hands, please wash it off well with soap and water

13. Precaution for Use

13.1

A limit sample should be provided by the both parties on an occasion when the both parties agreed its necessity. Judgment by a limit sample shall take effect after the limit sample has been established and confirmed by the both parties.

13.2

On the following occasions, the handing of problem should be decided through discussion and agreement between responsible of the both parties.

- When a question is arisen in this specification
- When a new problem is arisen which is not specified in this specifications
- When an inspection specifications change or operating condition change in customer is reported to YUXIANG TFT , and some problem is arisen in this specification due to the change
- When a new problem is arisen at the customer's operating set for sample evaluation in the customer site.

14. Packing Method

TBD