

**PRODUCT :** TFT TOUCH MODULE**MODULE NO. :** WKS50WV004-WCT**SUPPLIER:** WKS Technology Co.,LTD**DATE:** May 8, 2017

# SPECIFICATION

Revision: 0.0

**WKS50WV004-WCT**

This module uses ROHS material

This specification may change without prior notice in order to improve performance or quality. Please contact WKS R&D department for updated specification and product status before design for this product or release of this order.

<b>WRITTEN BY</b>	<b>CHECKED BY</b>	<b>APPROVED BY</b>
Jason	Liwen	Henry



## **CONTENTS**

- 1、 GENERAL INFORMATION**
- 2、 EXTERNAL DIMENSIONS**
- 3、 ABSOLUTE MAXIMUM RATINGS**
- 4、 ELECTRICAL CHARACTERISTICS**
- 5、 BACKLIGHT CHARACTERISTICS**
- 6、 CTP CHARACTERISTICS**
- 7、 ELECTRO-OPTICAL CHARACTERISTICS**
- 8、 INTERFACE DESCRIPTION**
- 9、 INPUT TIMING**
- 10、 RELIABILITY TEST CONDITIONS**
- 11、 INSPECTION CRITERION**

## 1、GENERAL INFORMATION

Item of general information	Contents		Unit
LCD Display Size(Diagonal)	5		inch
Module Structure	LCD Display + CTP Touch + PCB		-
LCD Display Type	TFT/TRANSMISSIVE		-
LCD Display Mode	Normally White		-
Recommended Viewing Direction	12		o'clock
Gray inversion Direction	6		o'clock
Module size (W×H×T)	136.00×76.05×7.27		mm
Active area (W×H)	108.00×64.80		mm
Number of pixels(Resolution)	800RGB×480		pixel
Pixel pitch (W×H)	0.135×0.135		mm
Color Pixel Arrangement	RGB Stripe		-
LCD Driver IC	-		-
Module Interface Type	LCD	RGB interface	-
	CTP	I2C interface	-
Module Input voltage	5.0V		V
Module Power consumption	-		mW
Color Numbers	65K		-
Backlight Type	White LED		-

## 2、EXTERNAL DIMENSIONS

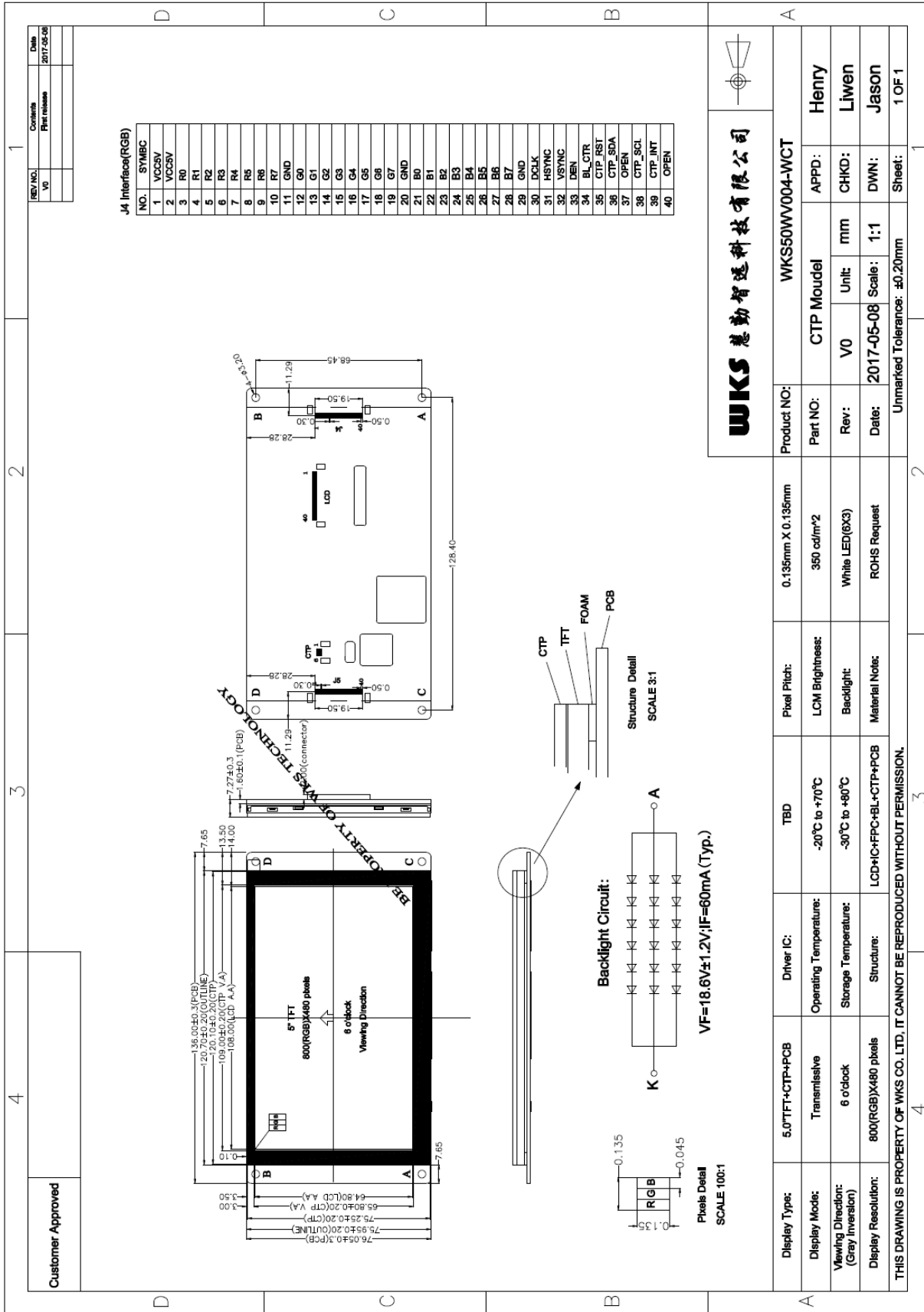

### 3、ABSOLUTE MAXIMUM RATINGS

Parameter of absolute maximum ratings	Symbol	Min	Max	Unit
Operating temperature	Top	-20	70	°C
Storage temperature	Tst	-30	80	°C
Humidity	RH	-	90%(Max 60°C)	RH

Note: Absolute maximum ratings means the product can withstand short-term, not more than 120 hours. If the product is a long time to withstand these conditions, the life time would be shorter.

### 4、ELECTRICAL CHARACTERISTICS(DC CHARACTERISTICS)

Parameter of DC characteristics	Symbol	Min.	Typ.	Max.	Unit
PCB operating voltage	VCC5V	-	5.0	-	V
LCD I/O operating voltage	VDD	2.3	3.3	3.6	V
Input voltage 'H' level	VIH	0.7*VDD	-	VDD	V
Input voltage 'L' level	VIL	VSS	-	0.3*VDD	V
Output voltage 'H' level	VOH	VDD-0.4	-	VDD	V
Output voltage 'L' level	VOL	VSS	-	VSS+0.4	V

### 5、 BACKLIGHT CHARACTERISTICS

Item of backlight characteristics	Symbol	Min.	Typ.	Max.	Unit	Remark
Forward Voltage	Vf	17.4	18.6	19.8	V	Note1
Forward Current	If	-	60	-	mA	-
Number of LED	-	-	6*3=18	-	Piece	-
LED Connection mode	P/S	-	Serial/Parallel	-	-	-
Lifetime of LED	-	-	10000	-	hour	Note2

Note:

- Note1: The LED Supply Voltage is defined by the number of LED at Ta=25°C and If=60mA.
- Note2: The LED lifetime define as the estimated time to 50% degradation of initial luminous. The LED lifetime could be decreased if operating If is lager than 60mA.
- Backlight control via the BL\_CTR pin or PWM signal.
- Backlight circuit:

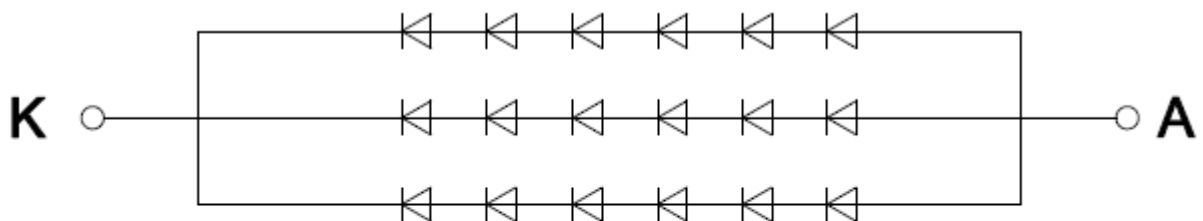

**VF=18.6V±1.2V;IF=60mA(Typ.)**

## 6、CTP CHARACTERISTICS

Item of CTP characteristics	Specification	Unit	Remark
Panel Type	Glass Cover + Glass Sensor	-	-
Resolution	800 × 480	pixel	-
Surface Hardness	6H	-	-
Transparency	≥82%	-	-
Driver IC	-	-	-
Interface Type	I2C	-	-
Support Points	5	-	-
Sampling Rate	20~100	Hz	-
Supply voltage	3.3	V	-



## 7、ELECTRO-OPTICAL CHARACTERISTICS

Item of electro-optical characteristics		Symbol	Condition	Min.	Typ.	Max.	Unit	Remark	Note
Response time		Tr+Tf	$\theta=0$ $\phi=0$ Ta=25°C	-	20	-	ms	FIG 1.	4
Contrast Ratio		CR		-	350	-	-	FIG 2.	1
Luminance uniformity		$\delta$ WHITE		-	80	-	%	FIG 2.	3
Surface Luminance		Lv		-	350	-	cd/m <sup>2</sup>	FIG 2.	2
CIE (x, y) chromaticity	White	White x	$\theta=0$ $\phi=0$ Ta=25°C	-	0.317	-	-	FIG 2.	5
		White y		-	0.324	-			
	Red	Red x		-	0.633	-			
		Red y		-	0.341	-			
	Green	Green x		-	0.324	-			
		Green y		-	0.551	-			
	Blue	Blue x		-	0.153	-			
		Blue y		-	0.143	-			
Viewing angle range	$\phi=90(12 \text{ o'clock})$		CR $\geq 10$	-	50	-	deg	FIG 3.	6
	$\phi=270(6 \text{ o'clock})$			-	60	-	deg		
	$\phi=0(3 \text{ o'clock})$			-	65	-	deg		
	$\phi=180(9 \text{ o'clock})$			-	65	-	deg		
NTSC ratio		-	-	-	50	-	%	-	-

**Note 1.** Contrast Ratio(CR) is defined mathematically by the following formula. For more information see FIG 2.:

$$\text{Contrast Ratio(CR)} = \frac{\text{Average Surface Luminance with all white pixels(P1,P2, P3, P4, P5, P6,P7, P8, P9)}}{\text{Average Surface Luminance with all black pixels(P1,P2, P3, P4, P5, P6,P7, P8, P9)}}$$

**Note 2.** Surface luminance is the LCD surface from the surface with all pixels displaying white. For more information see FIG 2.

Lv=Average Surface Luminance with all white pixels (P1,P2,P 3,P4, P5,P6,P7,P8,P9)

**Note 3.** The uniformity in surface luminance ( $\delta$ WHITE) is determined by measuring

luminance at each test position 1 through 9, and then dividing the maximum luminance of 9 points luminance by minimum luminance of 9 points luminance. For more information see FIG 2.

$$\delta_{\text{WHITE}} = \frac{\text{Minimum Surface Luminance with all white pixels (P1, P2, P3, P4, P5, P6, P7, P8, P9)}}{\text{Maximum Surface Luminance with all white pixels (P1, P2, P3, P4, P5, P6, P7, P8, P9)}}$$

**Note 4.** Response time is the time required for the display to transition from White to black(Rise Time,  $T_r$ ) and from black to white(Decay Time,  $T_f$ ). For additional information see FIG 1.

**Note 5.** CIE (x, y) chromaticity ,The x,y value is determined by screen active area position 5. For more information see FIG 2.

**Note 6.** Viewing angle is the angle at which the contrast ratio is greater than a specific value. For TFT module, the specific value of contrast ratio is 10.The angles are determined for the horizontal or x axis and the vertical or y axis with respect to the z axis which is normal to the LCD surface. For more information see FIG 3.

**Note 7.** For Viewing angle and response time testing, the testing data is base on Autronic-Melchers's ConoScope. Series Instruments. For contrast ratio, Surface Luminance, Luminance uniformity and CIE, the testing data is base on BM-7 photo detector.

**Note 8.** For TN type TFT transmissive module, Gray scale reverse occurs in the direction of panel viewing angle.

**FIG.1. The definition of Response Time**

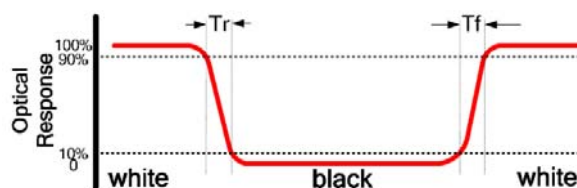

**FIG.2. Measuring method for Contrast ratio, surface luminance, Luminance**

**uniformity, CIE (x , y) chromaticity**

A : H/6 ;

B : V/6 ;

H,V : Active Area(AA) size

Measurement instrument: BM-7; Light spot size=5mm, 350mm distance from the LCD surface to detector lens.

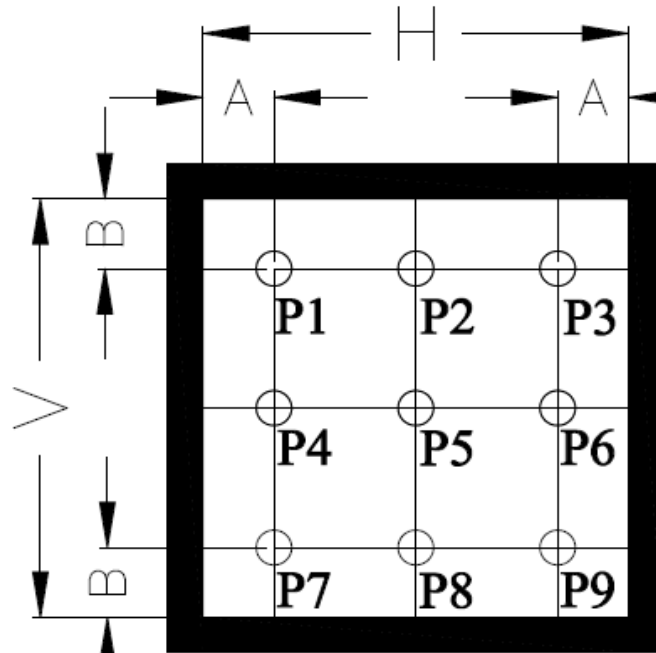

**FIG.3. The definition of viewing angle**

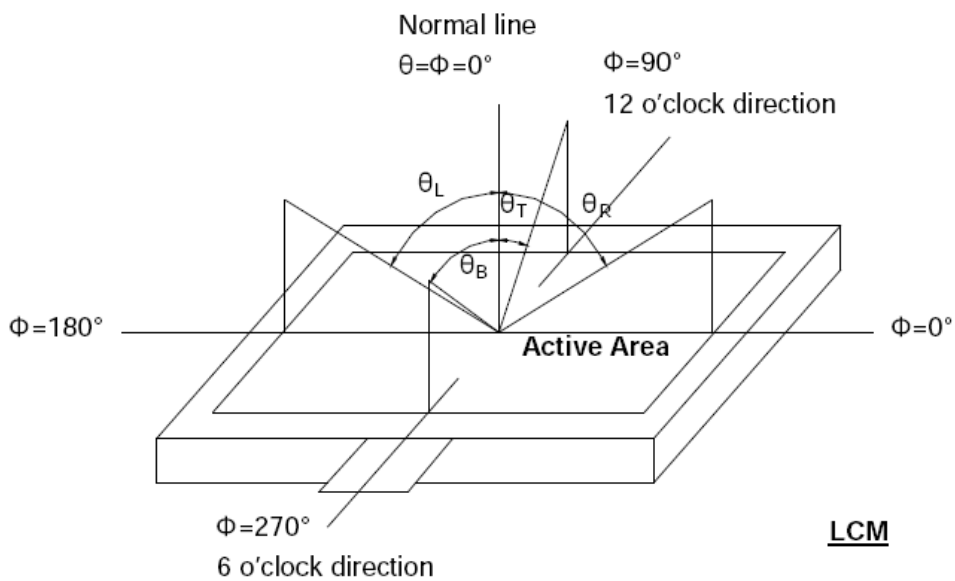

## 8、INTERFACE DESCRIPTION

NO.	Symbol	I/O	DESCRIPTION
1~2	VCC5V	Power supply	Module Power supply (5V Typ.)
3~10	R0~R7	I	8bit digital Red data input(R0:LSB; R7:MSB)
11	GND	Power supply	Power ground
12~19	G0~G7	I	8bit digital Green data input(G0:LSB; G7:MSB)
20	GND	Power supply	Power ground
21~28	B0~B7	I	8bit digital Blue data input(B0:LSB; B7:MSB)
29	GND	Power supply	Power ground
30	DCLK	I	Clock signal.
31	HSYNC	I	Horizontal Sync input.
32	VSYNC	I	Vertical Sync input.
33	DEN	I	Data input Enable.
34	BL_CTR	I	Backlight control pin
35	CTP_RST	I	CTP external reset signal, Low is active
36	CTP_SDA	I/O	CTP I2C data input and output
37	NC	-	No connection
38	CTP_SCL	I	CTP I2C clock input
39	CTP_INT	I	CTP External interrupt to the host
40	NC	-	No connection

### Application Note:

- 1、 For RGB565 Input Format: R3~R7, G2~G7, B3~B7 be used.
- 2、 For RGB666 Input Format: R2~R7, G2~G7, B2~B7 be used.

## 9、INPUT TIMING

### RGB Interface Data Format

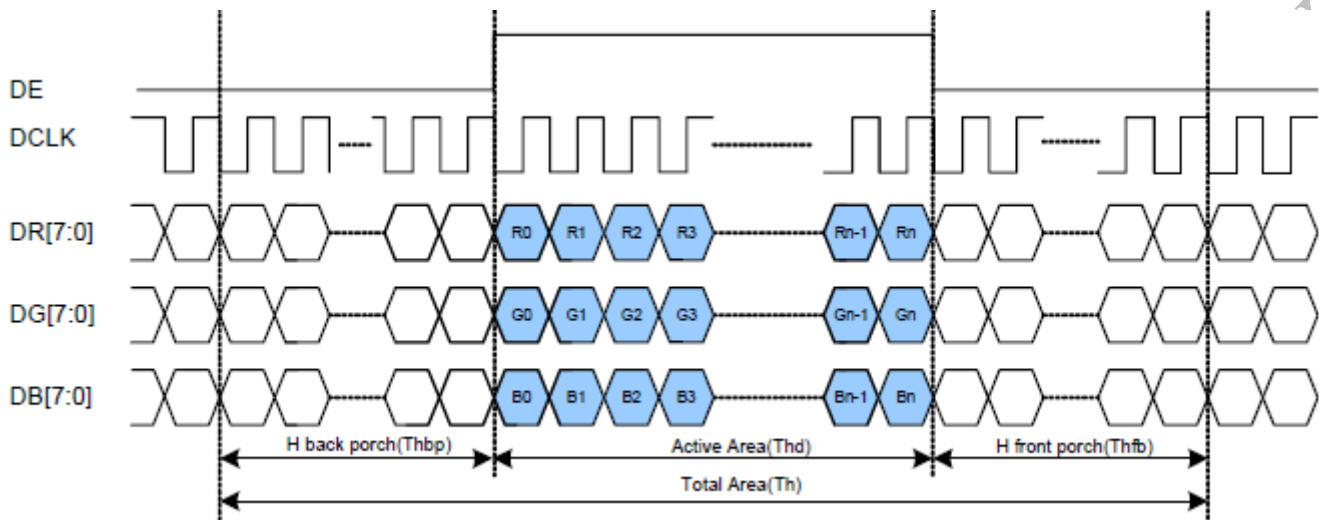

### RGB Interface Input Timing Table

Parameter	Symbol	Value			Unit
		Min.	Typ.	Max.	
DCLK frequency@ Frame rate=60Hz	DCLK	-	30	50	MHz
Horizontal display area	thd	800			DCLK
1 Horizontal Line	th	-	928	-	DCLK
HSYNC pulse width	thpw	1	48	-	DCLK
HSYNC Back Porch(Blanking)	thb	-	88	-	DCLK
HSYNC Front Porch	thfp	-	40	-	DCLK
Vertical display area	tvd	480			H
VSYNC period time	tv	-	525	-	H
VSYNC pulse width	tvpw	-	3	-	H
VSYNC Back Porch(Blanking)	tvb	-	32	-	H
VSYNC Front Porch	tvfp	-	13	-	H

## 10、RELIABILITY TEST CONDITIONS

No.	Test Item	Test Condition
1	High Temperature Storage	80°C/120 hours
2	Low Temperature Storage	-30°C/120 hours
3	High Temperature Operating	70°C/120 hours
4	Low Temperature Operating	-20°C/120 hours
5	Temperature Cycle Storage	-20°C(30min.)~25(5min.)~70°C(30min.)×10cycles

### A、 Inspection after test:

Inspection after 2~4 hours storage at room temperature, the sample shall be free from defects:

- Air bubble in the LCD;
- Sealleak;
- Non-display;
- Missing segments;
- Glass crack;
- Current is twice higher than initial value.

### B、 Remark:

- The test samples should be applied to only one test item.
- Sample size for each test item is 5~10pcs.
- Failure Judgment Criterion: Basic Specification, Electrical Characteristic, Mechanical Characteristic, Optical Characteristic.

## 11、INSPECTION CRITERION

This specification is made to be used as the standard of acceptance/rejection criteria for TFT-LCD/IPS TFT-LCD module product, and this specification is applicable only in the case that the size of module equal to or exceed than 4.3 inch.

### 11.1 Sample plan

Sampling plan according to GB/T2828.1-2003/ISO 2859-1: 1999 and ANSI/ASQC Z1.4-1993,normal level 2 and based on:

Major defect: AQL 0.65

Minor defect: AQL 1.5

### 11.2 Inspection condition

Viewing distance for cosmetic inspection is about 30cm with bare eyes, and under an environment of 20~40W light intensity, all directions for inspecting the sample should be within 45° against perpendicular line. (Normal temperature 20~25°C and normal humidity 60 ±15%RH )

### 11.3 Definition of Inspection Item.

A、 Definition of inspection zone in LCD.

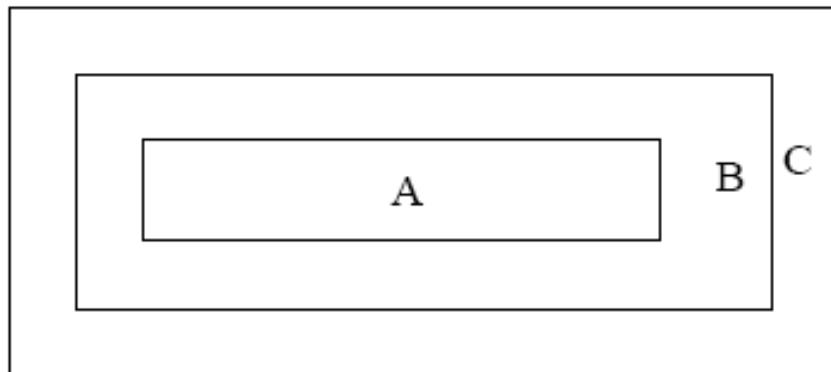

Zone A: character/Digit area

Zone B: viewing area except Zone A (Zone A + Zone B=minimum Viewing area)

Zone C: Outside viewing area (invisible area after assembly in customer's product)

Fig.1 Inspection zones in an LCD

Note: As a general rule, visual defects in Zone C are permissible, when it is no trouble for quality and assembly of customer's product.

### B、 Definition of some visual defect

Bright dot	Because of losing all or part function, bad pixel dots appear bright and the size is more than 50% of one dot in which LCD panel is displaying under black pattern.
Dark dot	Dots appear dark and unchanged in size in which LCD panel is displaying under pure red, green, blue picture, or pure whiter picture.

### 11.4 Major Defect

Item No.	Items to be inspected	Inspection standard	Classification of defects
1	Functional defects	1) No display 2) Display abnormally 3) Missing vertical, horizontal segment 4) Short circuit 5) Excess power consumption 6) Backlight no lighting, flickering and abnormal lighting	major
2	Missing	Missing component	
3	Outline dimension	Overall outline dimension beyond the drawing is not allowed	

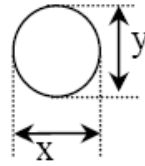

5、Minor Defect

Item No.	Items to be inspected	Inspection standard					Classification of defects																																														
1	Bright dot /dark dot defect	<table border="1"> <thead> <tr> <th colspan="2" data-bbox="464 517 783 645" rowspan="2">Zone</th> <th colspan="3" data-bbox="783 517 1235 555">Acceptable Qty</th> <th data-bbox="1166 517 1235 555" rowspan="2">C</th> </tr> <tr> <th colspan="3" data-bbox="783 555 1166 593">A+B</th> </tr> <tr> <th colspan="2" data-bbox="464 593 783 645"></th> <th data-bbox="783 593 906 645">4.3"~7"</th> <th data-bbox="906 593 1029 645">7~10.1"</th> <th data-bbox="1029 593 1166 645">&gt;10.1"</th> <th data-bbox="1166 593 1235 645"></th> </tr> </thead> <tbody> <tr> <td data-bbox="464 645 544 683">Bright pixel dot</td> <td data-bbox="544 645 783 683"></td> <td data-bbox="783 645 906 683">1</td> <td data-bbox="906 645 1029 683">2</td> <td data-bbox="1029 645 1166 683">3</td> <td data-bbox="1166 645 1235 683" rowspan="6">Acceptable</td> </tr> <tr> <td data-bbox="464 683 544 721">Dark pixel dot</td> <td data-bbox="544 683 783 721"></td> <td data-bbox="783 683 906 721">4</td> <td data-bbox="906 683 1029 721">4</td> <td data-bbox="1029 683 1166 721">4</td> </tr> <tr> <td data-bbox="464 721 544 759">2bright dots adjacent</td> <td data-bbox="544 721 783 759"></td> <td data-bbox="783 721 906 759">0</td> <td data-bbox="906 721 1029 759">0</td> <td data-bbox="1029 721 1166 759">0</td> </tr> <tr> <td data-bbox="464 759 544 797">2dark dots adjacent</td> <td data-bbox="544 759 783 797"></td> <td data-bbox="783 759 906 797">0</td> <td data-bbox="906 759 1029 797">0</td> <td data-bbox="1029 759 1166 797">0</td> </tr> <tr> <td data-bbox="464 797 544 835">Total bright and dark dots</td> <td data-bbox="544 797 783 835"></td> <td data-bbox="783 797 906 835">5</td> <td data-bbox="906 797 1029 835">6</td> <td data-bbox="1029 797 1166 835">7</td> </tr> <tr> <td data-bbox="464 835 544 873"></td> <td data-bbox="544 835 783 873"></td> <td data-bbox="783 835 906 873"></td> <td data-bbox="906 835 1029 873"></td> <td data-bbox="1029 835 1166 873"></td> </tr> </tbody> </table> <p data-bbox="464 907 1235 1025">Note: Minimum distance between defective dots is more than 5mm; Pixel dots' function is normal, but bright dots caused by foreign material and other reasons are judged by the dot defect of 5.2.</p>					Zone		Acceptable Qty			C	A+B					4.3"~7"	7~10.1"	>10.1"		Bright pixel dot		1	2	3	Acceptable	Dark pixel dot		4	4	4	2bright dots adjacent		0	0	0	2dark dots adjacent		0	0	0	Total bright and dark dots		5	6	7						Minor
Zone		Acceptable Qty			C																																																
		A+B																																																			
		4.3"~7"	7~10.1"	>10.1"																																																	
Bright pixel dot		1	2	3	Acceptable																																																
Dark pixel dot		4	4	4																																																	
2bright dots adjacent		0	0	0																																																	
2dark dots adjacent		0	0	0																																																	
Total bright and dark dots		5	6	7																																																	
2	<p data-bbox="256 1153 427 1191">Dot defect</p>  <p data-bbox="256 1377 427 1415"><math>\Phi = (x+y) / 2</math></p>	<table border="1"> <thead> <tr> <th colspan="2" data-bbox="464 1032 699 1160" rowspan="2">Zone</th> <th colspan="3" data-bbox="699 1032 1235 1070">Acceptable Qty</th> <th data-bbox="1166 1032 1235 1070" rowspan="2">C</th> </tr> <tr> <th colspan="3" data-bbox="699 1070 1166 1108">A+B</th> </tr> <tr> <th colspan="2" data-bbox="464 1108 699 1160">Size(mm)</th> <th data-bbox="699 1108 847 1160">4.3"~7"</th> <th data-bbox="847 1108 1002 1160">7~10.1"</th> <th data-bbox="1002 1108 1166 1160">&gt;10.1"</th> <th data-bbox="1166 1108 1235 1160"></th> </tr> </thead> <tbody> <tr> <td data-bbox="464 1160 544 1227"><math>\Phi \leq 0.2</math></td> <td data-bbox="544 1160 699 1227"></td> <td data-bbox="699 1160 847 1227">Acceptable</td> <td data-bbox="847 1160 1002 1227">Acceptable</td> <td data-bbox="1002 1160 1166 1227">Acceptable</td> <td data-bbox="1166 1160 1235 1227" rowspan="3">Acceptable</td> </tr> <tr> <td data-bbox="464 1227 544 1294"><math>0.2 &lt; \Phi \leq 0.5</math></td> <td data-bbox="544 1227 699 1294"></td> <td data-bbox="699 1227 847 1294">4</td> <td data-bbox="847 1227 1002 1294">5</td> <td data-bbox="1002 1227 1166 1294">6</td> </tr> <tr> <td data-bbox="464 1294 544 1355"><math>\Phi &gt; 0.5</math></td> <td data-bbox="544 1294 699 1355"></td> <td data-bbox="699 1294 847 1355">0</td> <td data-bbox="847 1294 1002 1355">0</td> <td data-bbox="1002 1294 1166 1355">0</td> </tr> </tbody> </table> <p data-bbox="464 1355 1235 1473">Note: 1. Minimum distance between defective dots is more than 5 mm; 2. The quantity of defect is zero in operating condition.</p>					Zone		Acceptable Qty			C	A+B			Size(mm)		4.3"~7"	7~10.1"	>10.1"		$\Phi \leq 0.2$		Acceptable	Acceptable	Acceptable	Acceptable	$0.2 < \Phi \leq 0.5$		4	5	6	$\Phi > 0.5$		0	0	0	Minor															
Zone		Acceptable Qty			C																																																
		A+B																																																			
Size(mm)		4.3"~7"	7~10.1"	>10.1"																																																	
$\Phi \leq 0.2$		Acceptable	Acceptable	Acceptable	Acceptable																																																
$0.2 < \Phi \leq 0.5$		4	5	6																																																	
$\Phi > 0.5$		0	0	0																																																	
3	Linear defect	<table border="1"> <thead> <tr> <th colspan="2" data-bbox="464 1525 699 1653" rowspan="2">Zone</th> <th colspan="3" data-bbox="699 1525 1235 1563">Acceptable Qty</th> <th data-bbox="1166 1525 1235 1563" rowspan="2">C</th> </tr> <tr> <th colspan="3" data-bbox="699 1563 1166 1601">A+B</th> </tr> <tr> <th colspan="2" data-bbox="464 1601 699 1653">Size (mm)</th> <th data-bbox="699 1601 847 1653">4.3"~7"</th> <th data-bbox="847 1601 1002 1653">7~10.1"</th> <th data-bbox="1002 1601 1166 1653">&gt;10.1"</th> <th data-bbox="1166 1601 1235 1653"></th> </tr> </thead> <tbody> <tr> <td data-bbox="464 1653 544 1691">Length</td> <td data-bbox="544 1653 699 1691">Width</td> <td data-bbox="699 1653 847 1691"></td> <td data-bbox="847 1653 1002 1691"></td> <td data-bbox="1002 1653 1166 1691"></td> <td data-bbox="1166 1653 1235 1691" rowspan="4">Acceptable</td> </tr> <tr> <td data-bbox="464 1691 544 1729">Ignore</td> <td data-bbox="544 1691 699 1729"><math>W \leq 0.05</math></td> <td data-bbox="699 1691 847 1729">Acceptable</td> <td data-bbox="847 1691 1002 1729">Acceptable</td> <td data-bbox="1002 1691 1166 1729">Acceptable</td> </tr> <tr> <td data-bbox="464 1729 544 1767"><math>L \leq 5.0</math></td> <td data-bbox="544 1729 699 1767"><math>0.05 &lt; W \leq 0.1</math></td> <td data-bbox="699 1729 847 1767">4</td> <td data-bbox="847 1729 1002 1767">5</td> <td data-bbox="1002 1729 1166 1767">6</td> </tr> <tr> <td data-bbox="464 1767 544 1805"><math>L &gt; 5.0</math></td> <td data-bbox="544 1767 699 1805"><math>W &gt; 0.1</math></td> <td data-bbox="699 1767 847 1805">0</td> <td data-bbox="847 1767 1002 1805">0</td> <td data-bbox="1002 1767 1166 1805">0</td> </tr> </tbody> </table>					Zone		Acceptable Qty			C	A+B			Size (mm)		4.3"~7"	7~10.1"	>10.1"		Length	Width				Acceptable	Ignore	$W \leq 0.05$	Acceptable	Acceptable	Acceptable	$L \leq 5.0$	$0.05 < W \leq 0.1$	4	5	6	$L > 5.0$	$W > 0.1$	0	0	0	Minor										
Zone		Acceptable Qty			C																																																
		A+B																																																			
Size (mm)		4.3"~7"	7~10.1"	>10.1"																																																	
Length	Width				Acceptable																																																
Ignore	$W \leq 0.05$	Acceptable	Acceptable	Acceptable																																																	
$L \leq 5.0$	$0.05 < W \leq 0.1$	4	5	6																																																	
$L > 5.0$	$W > 0.1$	0	0	0																																																	

<p>4</p>	<p>Polarizer defect</p>	<p>5.4.1 Polarizer Position                  (i) Shifting in position should not exceed the glass outline dimension.                  (ii) Incomplete covering of the viewing area due to shifting is not allowed.</p> <p>5.4.2 Dirt on polarizer                  Dirt which can be wiped easily should be acceptable.</p> <p>5.4.3 Polarizer Dent &amp; Air bubble</p> <table border="1" data-bbox="464 517 1235 837"> <thead> <tr> <th rowspan="3">Zone Size(mm)</th> <th colspan="3">Acceptable Qty</th> <th rowspan="3">C</th> </tr> <tr> <th colspan="3">A+B</th> </tr> <tr> <th>4.3''~7''</th> <th>7~10.1''</th> <th>&gt;10.1''</th> </tr> </thead> <tbody> <tr> <td><math>\Phi \leq 0.2</math></td> <td>Acceptable</td> <td>Acceptable</td> <td>Acceptable</td> <td rowspan="3">Acceptable</td> </tr> <tr> <td><math>0.2 &lt; \Phi \leq 0.5</math></td> <td>4</td> <td>5</td> <td>6</td> </tr> <tr> <td><math>\Phi &gt; 0.5</math></td> <td>0</td> <td>0</td> <td>0</td> </tr> </tbody> </table> <p>5.4.4 Polarizer scratch                  (i) If the polarizer scratch can be seen after cover assembling or in the operating condition, judge by the linear defect of 5.3.                  (ii) If the polarizer scratch can be seen only in non-operating condition or some special angle, judge by the following:</p> <table border="1" data-bbox="464 1043 1235 1444"> <thead> <tr> <th colspan="2">Zone</th> <th colspan="3">Acceptable Qty</th> <th rowspan="3">C</th> </tr> <tr> <th colspan="2">Size (mm)</th> <th colspan="3">A+B</th> </tr> <tr> <th>Length</th> <th>Width</th> <th>4.3''~7''</th> <th>7~10.1''</th> <th>&gt;10.1''</th> </tr> </thead> <tbody> <tr> <td>Ignore</td> <td><math>W \leq 0.05</math></td> <td>Acceptable</td> <td>Acceptable</td> <td>Acceptable</td> <td rowspan="3">Acceptable</td> </tr> <tr> <td><math>1.0 &lt; L \leq 5.0</math></td> <td><math>0.05 &lt; W \leq 0.20</math></td> <td>4</td> <td>5</td> <td>6</td> </tr> <tr> <td><math>L &gt; 5.0</math></td> <td><math>W &gt; 0.2</math></td> <td>0</td> <td>0</td> <td>0</td> </tr> </tbody> </table>	Zone Size(mm)	Acceptable Qty			C	A+B			4.3''~7''	7~10.1''	>10.1''	$\Phi \leq 0.2$	Acceptable	Acceptable	Acceptable	Acceptable	$0.2 < \Phi \leq 0.5$	4	5	6	$\Phi > 0.5$	0	0	0	Zone		Acceptable Qty			C	Size (mm)		A+B			Length	Width	4.3''~7''	7~10.1''	>10.1''	Ignore	$W \leq 0.05$	Acceptable	Acceptable	Acceptable	Acceptable	$1.0 < L \leq 5.0$	$0.05 < W \leq 0.20$	4	5	6	$L > 5.0$	$W > 0.2$	0	0	0	<p>Minor</p>
Zone Size(mm)	Acceptable Qty			C																																																							
	A+B																																																										
	4.3''~7''	7~10.1''	>10.1''																																																								
$\Phi \leq 0.2$	Acceptable	Acceptable	Acceptable	Acceptable																																																							
$0.2 < \Phi \leq 0.5$	4	5	6																																																								
$\Phi > 0.5$	0	0	0																																																								
Zone		Acceptable Qty			C																																																						
Size (mm)		A+B																																																									
Length	Width	4.3''~7''	7~10.1''	>10.1''																																																							
Ignore	$W \leq 0.05$	Acceptable	Acceptable	Acceptable	Acceptable																																																						
$1.0 < L \leq 5.0$	$0.05 < W \leq 0.20$	4	5	6																																																							
$L > 5.0$	$W > 0.2$	0	0	0																																																							
<p>5</p>	<p>MURA</p> <p>White/Black dot (MURA)</p>	<p>Using 3% ND filter, it's NG if it can be seen in R,G,B picture.</p> <p>Visible under: ND3%; <math>D \leq 0.15\text{mm}</math>, Acceptable;  <math>0.15\text{mm} &lt; D \leq 0.5\text{mm}</math>, <math>N \leq 4</math>; <math>D &gt; 0.5\text{mm}</math>, Not allowable.</p>	<p>Minor</p>																																																								

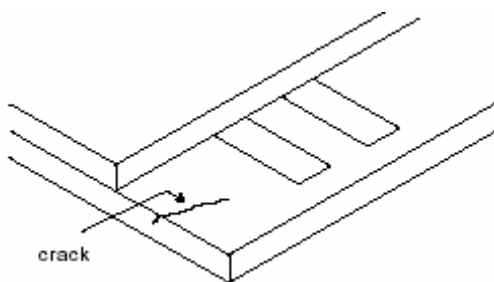
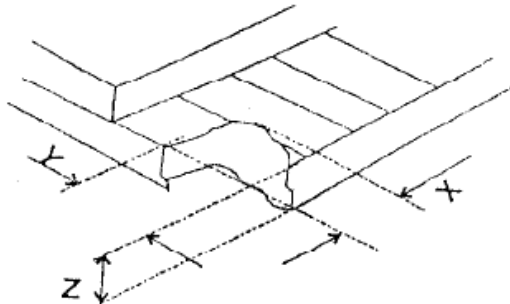
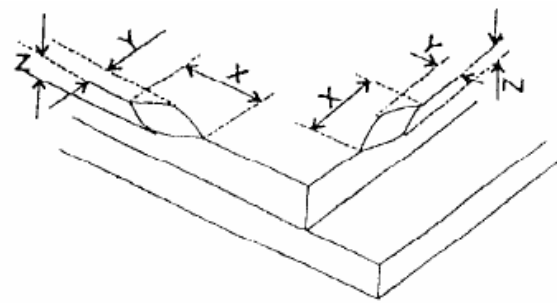
6	Glass defect	<p>(i) Crack Cracks are not allowed.</p> 	Minor								
		<p>(ii) TFT chips on corner</p>  <table border="1" data-bbox="462 929 1236 1064"> <thead> <tr> <th>X</th> <th>Y</th> <th>Z</th> <th>Acceptable</th> </tr> </thead> <tbody> <tr> <td><math>\leq 3.0</math></td> <td><math>\leq 3.0</math></td> <td>Not more than the thickness of glass</td> <td><math>N \leq 3</math></td> </tr> </tbody> </table> <p>Chips on the corner of terminal shall not be allowed to extend into the ITO pad or expose perimeter seal.</p>	X	Y	Z	Acceptable	$\leq 3.0$	$\leq 3.0$	Not more than the thickness of glass	$N \leq 3$	Minor
		X	Y	Z	Acceptable						
$\leq 3.0$	$\leq 3.0$	Not more than the thickness of glass	$N \leq 3$								
<p>(iii) Usual surface crack</p>  <table border="1" data-bbox="462 1512 1236 1646"> <thead> <tr> <th>X</th> <th>Y</th> <th>Z</th> <th>Acceptable</th> </tr> </thead> <tbody> <tr> <td><math>\leq 1.5</math></td> <td><math>\leq 1.5</math></td> <td>Not more than the thickness of glass</td> <td><math>N \leq 4</math></td> </tr> </tbody> </table> <p>It is only applicable to the upper glass of LCD.</p>	X	Y	Z	Acceptable	$\leq 1.5$	$\leq 1.5$	Not more than the thickness of glass	$N \leq 4$	Minor		
X	Y	Z	Acceptable								
$\leq 1.5$	$\leq 1.5$	Not more than the thickness of glass	$N \leq 4$								

## 11.6 Module Cosmetic Criteria

Item No.	Items to be inspected	Inspection Standard	Classification of defects
1	Difference in Spec.	Not allowable	Major
2	Pattern peeling	No substrate pattern peeling and floating	Major
3	Soldering defects	No soldering missing	Major
		No soldering bridge	Major
		No cold soldering	Minor
4	Resist flaw on PCB	Visible copper foil ( $\Phi 0.5$ mm or more) on substrate pattern is not allowed	Minor
5	FPC gold finger	No dirt, breaking, oxidation lead to black	Major
6	Backlight plastic frame	No deformation, crack, breaking, backlight positioning column breaking, obvious nick.	Minor
7	Marking printing effect	No dark marking, incomplete, deformation lead to unable to judge	Minor
8	Accretion of metallic Foreign matter	No accretion of metallic foreign matter (Not exceed $\Phi 0.2$ mm)	Minor
9	Stain	No stain to spoil cosmetic badly	Minor
10	Plate discoloring	No plate fading, rusting and discoloring	Minor
11	1. Lead parts	a. Soldering side of PCB Solder to form a 'Filet' all around the lead. Solder should not hide the lead form perfectly.	Minor
		b. Components side(In case of 'Through Hole PCB') Solder to reach the Components side of PCB.	Minor
	2. Flat packages	Either 'Toe'(A) or 'Seal'(B)of the lead to be covered by "Filet". Lead form to be assume over Solder.	Minor
	3. Chips	$(3/2) H \geq h \geq (1/2) H$	Minor
4. Solder ball/Solder splash	a. The spacing between solder ball and the conductor or solder pad $h \geq 0.13$ mm. The diameter of solder ball $d \leq 0.15$ mm.	Minor	
	b. The quantity of solder balls or solder splashes isn't beyond 5 in 600 mm <sup>2</sup> .	Minor	
	c. Solder balls/Solder splashes do not violate minimum electrical clearance.	Major	

