



# **Servo Motor Controller Instructions**

## **for use**

**Ver 3.4**

**Parameters:**

Hardware	32 channels	24 channels	16 channels
Operating Voltage	5V	5V	5V
Servo Motor Input Voltage	According to the servo	According to the servo	According to the servo
CPU	32bit	32bit	32bit
Baud Rate (USB)	115200	115200	115200
Baud Rate (Bluetooth, WIFI, UART)	4800, 9600, 19200, 38400, 57600, 115200	4800, 9600, 19200, 38400, 57600, 115200	4800, 9600, 19200, 38400, 57600, 115200
Flash Capacity	16M	16M	16M
Servo motor synchronous quantity	32	24	16
Max Action Groups	255	255	255
control precision	1us	1us	1us
Servo Motor signal isolation	Yes	Yes	Yes
Current limiting protection	No	Yes	Yes
MPU6500	No	Yes	NO
External sensor support	No	No	Yes
3D Virtual	All	All	Part
Indicator led	1.CPU power indicator led (red) 2.Servo motor power indicator led (green) 3. wireless remote control (Yellow)	1.CPU power indicator led (red) 2.Servo motor power indicator led (green) 3.wireless remote control (Yellow)	1.CPU power indicator led (red) 2.Servo motor power indicator led (green) 3.wireless remote control (Yellow)
Size	64mm X 45mm	64mm X 47.5mm	58.5mm x 45mm
Communication Protocol	UART	UART	UART
Computer Software	Windows XP or later, Mac OS 10.8 or later ,Linux(kernel 3.0 or later)	Windows XP or later, Mac OS 10.8 or later ,Linux(kernel 3.0 or later)	Windows XP or later, Mac OS 10.8 or later ,Linux(kernel 3.0 or later)
Low pressure alarm	Default Open	Default Open	Default Open
Servo motor initial value	Default 1500	Default 1500	Default 1500
Support The Servo motor Type	9G~55G	9G~55G	
Online Operations Support	C51, Arduino, ARM, MSP, DSP, WIFI, Bluetooth, Compute	C51, Arduino, ARM, MSP, DSP, WIFI, Bluetooth, Computer	C51, Arduino, ARM, MSP, DSP, WIFI, Bluetooth, Computer
wireless remote control	1. one servo motor control 2. action groups control	1. one servo motor control 2. action groups control	1. one servo motor control 2. action groups control

**32 channels:**

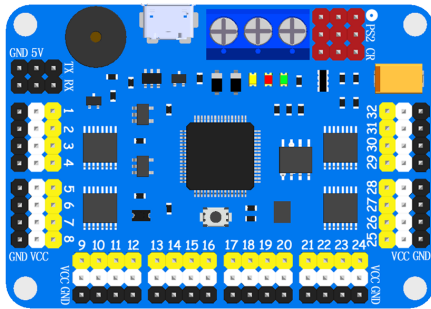

**24 channels:**

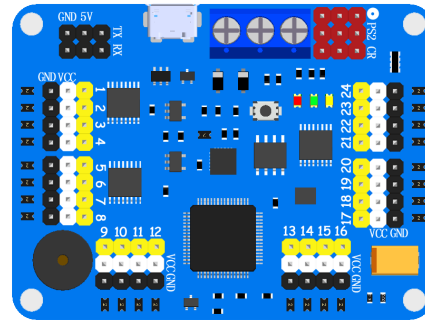

**16 channels:**

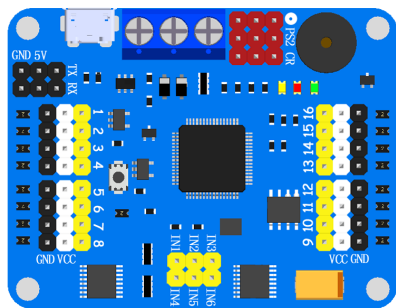

R R O B O T

# Instruction:

## Communication Protocol:

serial communication	baud rate	parity bit	data bits	stop bits
TTL	9600(default)	none	8	1

## Instruction format:

name	Instruction	description
Controller single servo	#1P1500T1000D800\r\n	Data 1 refers to the servo' s channel Data 1500 Refers to the servo' s location, in the range 500-2500 Data 1000 refers to the time of execution and represents the speed, in the range 100-9999 Data 800 refers to the Instruction interval of delay time, in the range 100-9999
Controller multiple servo	#1P1500#2P1500T1000D800\r\n	Data 1、 2 refers to the servo' s channel Data 1500 Refers to the servo' s location, in the range 500-2500 Data 1000 refers to the time of execution and represents the speed, in the range 100-9999 Data 800 refers to the Instruction interval of delay time, in the range 100-9999
Run action groups	G1F3\r\n	Data 1 refers to the group' s channel Data 3 refers to the frequency of runs
Stop action groups	~ST	Stop running action groups (Note: not pause)

**Note:** "\r\n" converted to hexadecimal is "0x0D 0x0A" ;All instruction is ASCII.

"0x0D" == "\r" == "CR"

"0x0A" == "\n" == "LF"

Tip: If the function or software used in the program has "\r\n" , it is not necessary to add it at the end. When the instruction is completed Controller feedback "OK" .

## Wiring methods:

### I. Power supply access method, *P.1* location:

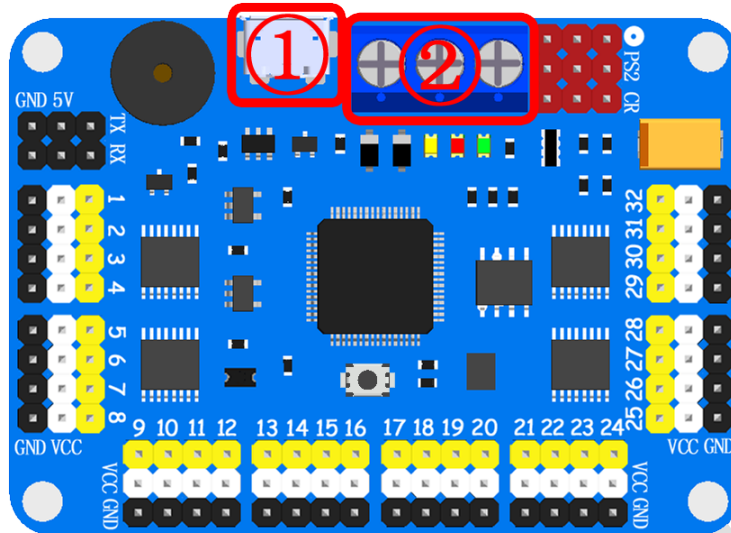

*P.1*

**VCC:** Servo motor power input VCC, can be connected to 4.2 V ~ 7.2 V power supply; plugged into power supply for the anode, please.

**GND:** The overall GND of servo motor controller, can be connected to servo motor power GND or CPU power GND; plugged into power supply for the cathode, please.

**5V:** Servo motor controller CPU power input, Voltage range:5V~8.5V.

**USB(①):** Servo motor controller CPU power input and data communication port.

**Note:** 5V interface and USB interface can not access the power supply at the same time. Only one can be selected as the power interface

## II. Servo motor access method, P.2 location:

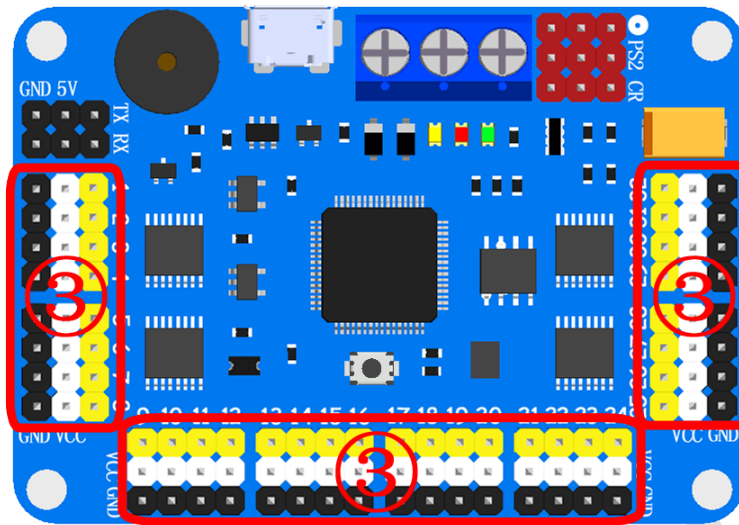

*P.2*

**Yellow Pin:** Servo motor I/O connected with the entrance, it usual be servo motor yellow or yellow soil.

**White Pin:** Servo motor VCC connected with the entrance, it usual be servo motor red or dark red.

**Black Pin:** Servo motor GND connected with the entrance, it usual be servo motor brown or black.

### III. UART access method, *P.3* location, with the *P.4* reading:

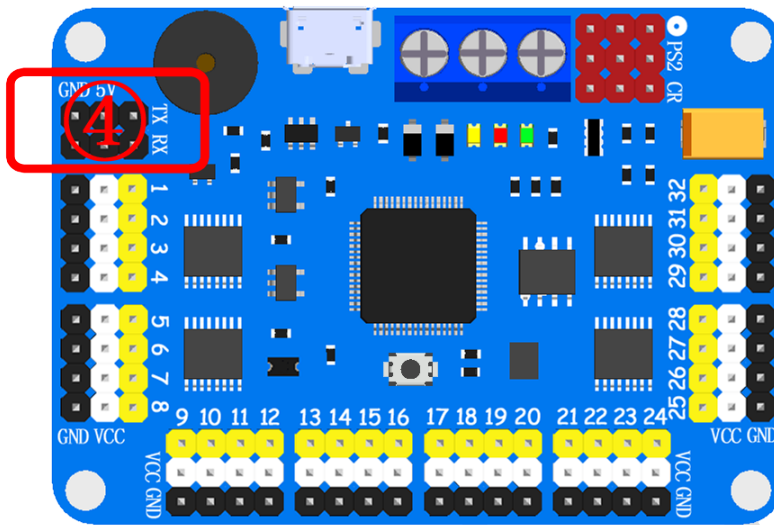

*P.3*

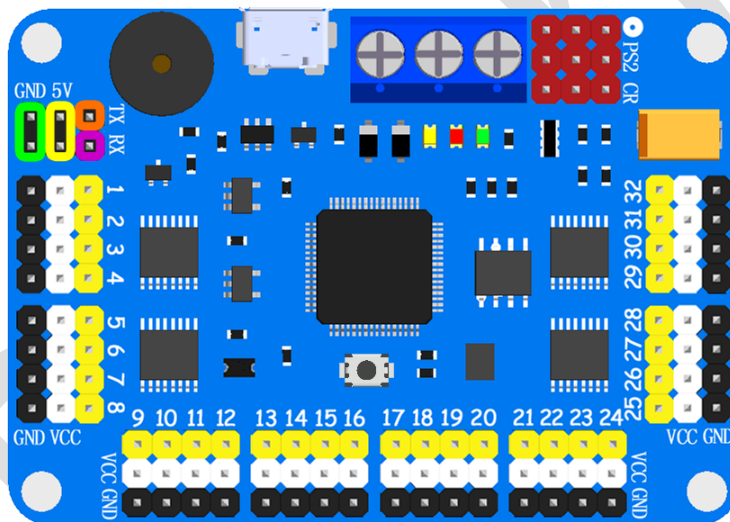

*P.4*

**Green circle position:** CPU power input of GND for servo motor controller.

**Yellow circle position:** CPU power input of VCC for servo motor controller.

**Purple circle position:** UART RX port for servo motor controller.

**Orange circle position:** UART TX port for servo motor controller.

#### IV. Bluetooth and WIFI sensor access method, *P.5* location:

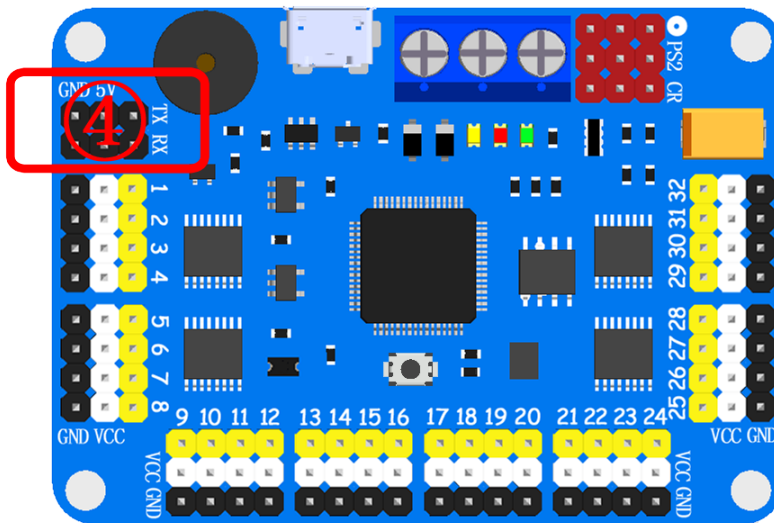

*P.5*

*P.5* location, use four lines to line the Bluetooth sensor, 5V-VCC, GND-GND, RX-TX, TX-RX.

Pairing your phone with a Bluetooth module, and Install app.

Fill in WIFI module settings TCP address can be controlled.

first time use app must input "RTrobot".



## V. wireless remote control access method, *P.6* location:

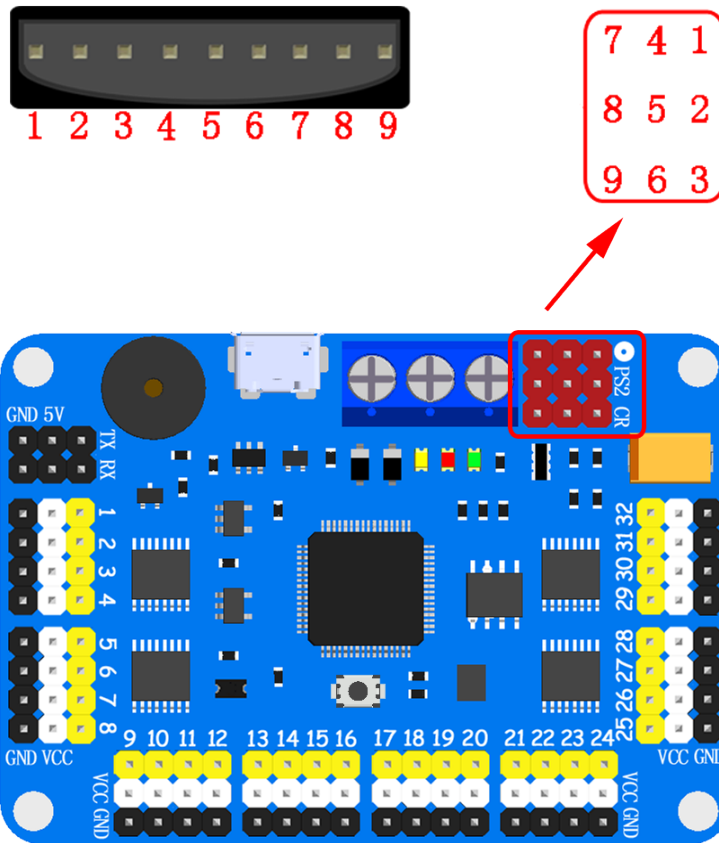

*P.6*

Using the wireless remote control receiver and servo motor controller linked together. like *P.6*, 1-1、 2-2、 3-3....., don't forget the handle also need two batteries.

Wireless remote control have two mode, mode one is one of the servo motor to control (LED ON) , mode two is action groups operations(LED OFF). At different mode, the button have different function; but, have some buttons in both modes are same.

**Note:** After power-up, you must pass a "START" to start servo.

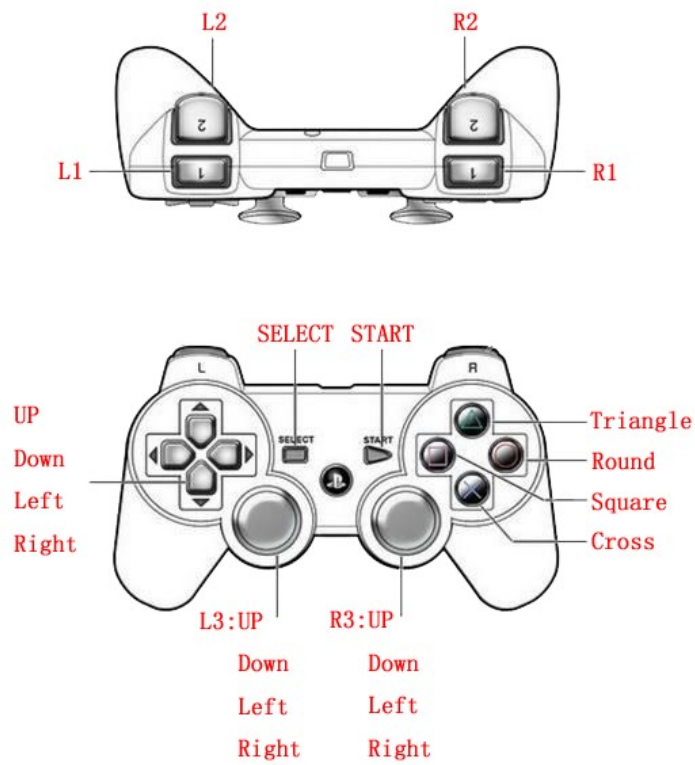

## P.7

### Same push buttons:

**SELECT:** Exchange modes

**START:** Start to work

### One of the servo motor to control:

**Square:** All servo motor moves to 2500

**Cross:** All servo motor moves to 1500

**Round:** All servo motor moves to 500

**Triangle:** None

Hardware	32 channels	24 channels	16 channels
Number of the first group of servo motors	1, 3, 5, 7, 9, 11, 13, 15	1, 3, 5, 7, 9, 11	1, 3, 5, 7
The first group of push button	<b>L2:</b> Exchange group one servo, descending order <b>R2:</b> Exchange group one servo, ascending order <b>L3-Left:</b> Group one servo motor value increased <b>L3-Right:</b> Group one servo motor value reduced		
Number of the second group of servo motors	2, 4, 6, 8, 10, 12, 14, 16	2, 4, 6, 8, 10, 12	2, 4, 6, 8
The second group of push button	<b>L1:</b> Exchange group two servo, descending order <b>R1:</b> Exchange group two servo, ascending order <b>R3-Left:</b> Group two servo motor value increased <b>R3-Right:</b> Group two servo motor value reduced		
Number of the third group of servo motors	17, 19, 21, 23, 25, 27, 29, 31	13, 15, 17, 19, 21, 23	9, 11, 13, 15
The third group of push button	<b>Left:</b> Exchange group three servo, descending order <b>Right:</b> Exchange group three servo, ascending order <b>L3-Up:</b> Group three servo motor value increased <b>L3-Down:</b> Group three servo motor value reduced		
Number of the fourth group of servo motors	18, 20, 22, 24, 26, 28, 30, 32	14, 16, 18, 20, 22, 24	10, 12, 14, 16
The fourth group of push button	<b>Down:</b> Exchange group four servo, descending order <b>Up:</b> Exchange group four servo, ascending order <b>R3-Up:</b> Group four servo motor value increased <b>R3-Down:</b> Group four servo motor value reduced		

### Action groups to control:

Push Button	<b>L2</b>	<b>L1</b>	<b>R2</b>	<b>R1</b>	<b>Up</b>	<b>Left:</b>
action group	0	1	2	3	4	5
Push Button	<b>Down</b>	<b>Right</b>	<b>L3-Up</b>	<b>L3-Left</b>	<b>L3-Down</b>	<b>L3-Right</b>
action group	6	7	8	9	10	11
Push Button	<b>R3-Up</b>	<b>R3-Left</b>	<b>R3-Down</b>	<b>R3-Right</b>	<b>Square</b>	<b>Cross</b>
action group	12	13	14	15	16	17
Push Button	<b>Round</b>	<b>Triangle</b>				
action group	18	19				

If you need a custom handle button function, please click "Setting" - > "Wireless controller" in the editor.

## Overall Wiring example:

### I . use of computer-controlled :

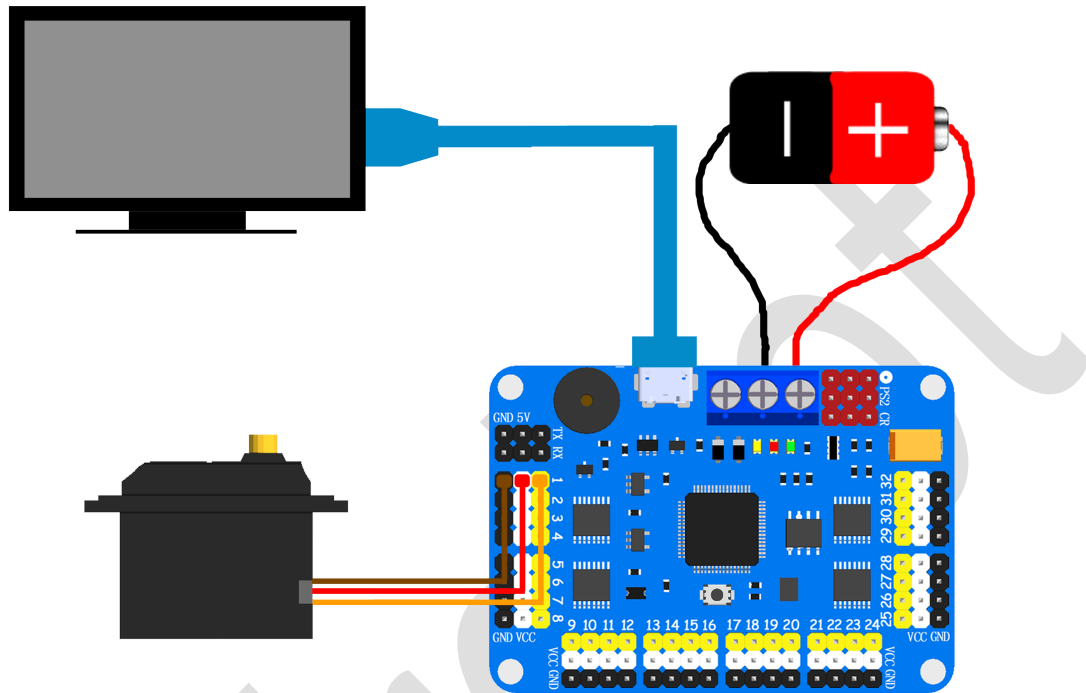

#### **P.8**

Use the USB line to Computer and servo motor controller linked together.

The power of the servo motor access please reference **Wiring methods: I** (don't use VDD interface).



### III. Using MCU to control

Servo motor controller of power supply to the MCU:

Here is an example with Arduino UNO, Other MCU can reference here. Servo motor controller 5V link Arduino UNO 5V, Servo motor controller GND link Arduino UNO GND, Servo motor controller TX link Arduino UNO RX, Servo motor controller RX link Arduino UNO TX. like **P.10**:

**NOTE:** Note: all of the power supply is powered by one battery.

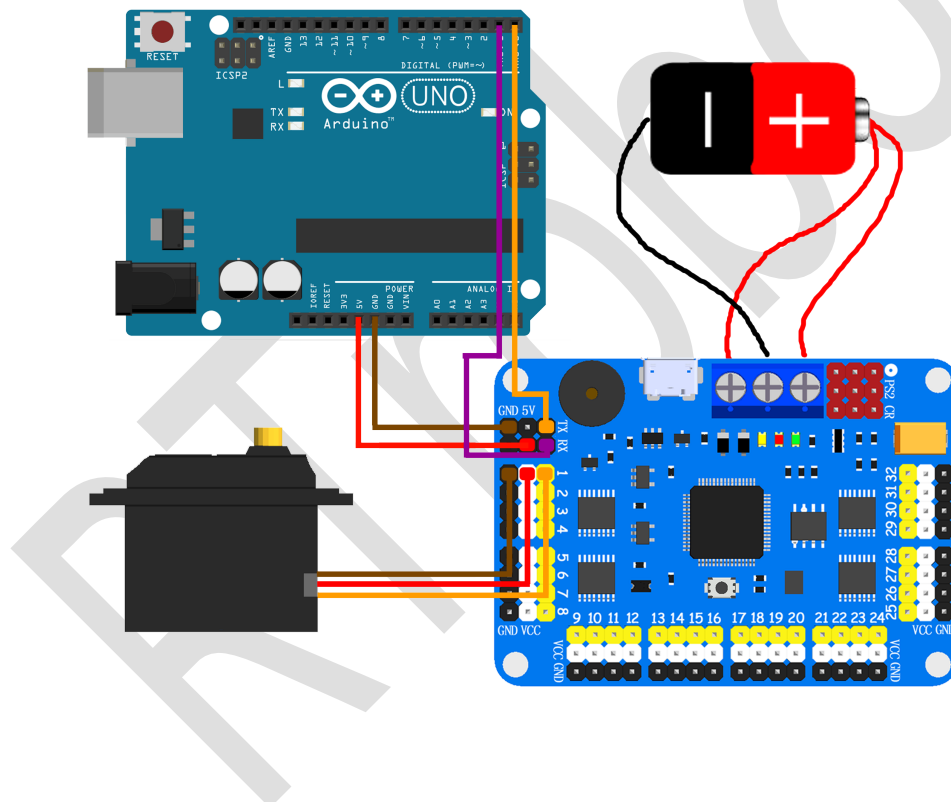

**P.10**

MCU power supply to the servo motor controller:

Servo motor controller 5V link Arduino UNO 5V, Servo motor controller GND link Arduino UNO GND, Servo motor controller TX link Arduino UNO RX, Servo motor controller RX link Arduino UNO TX.

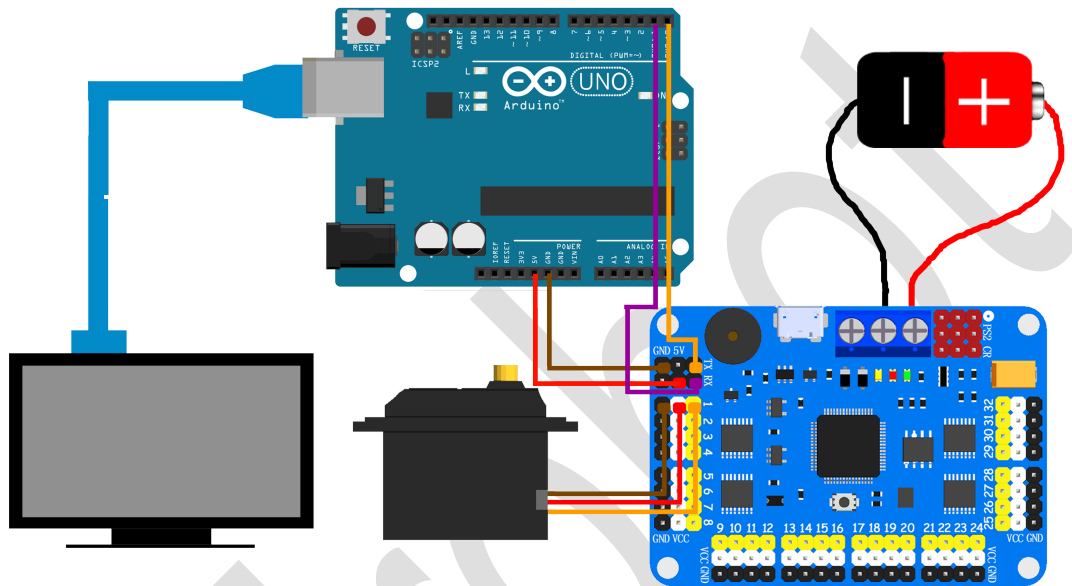

### P.11

Note: the UNO Arduino and the Servo motor controller provide power through the computer. The servo motor is an independent power supply.

# Software Operation:

## I . Software Settsing:

Check "Setting" -> "Software" , You can set up the software, like **P.12**.

Servo Value: Set up max value and mix value of servo motor.

Software Panel: Set up software control panel.

Servo On/Off: Hide the servo motor are not used.

After completion of the software configuration will automatically restart the softw are.

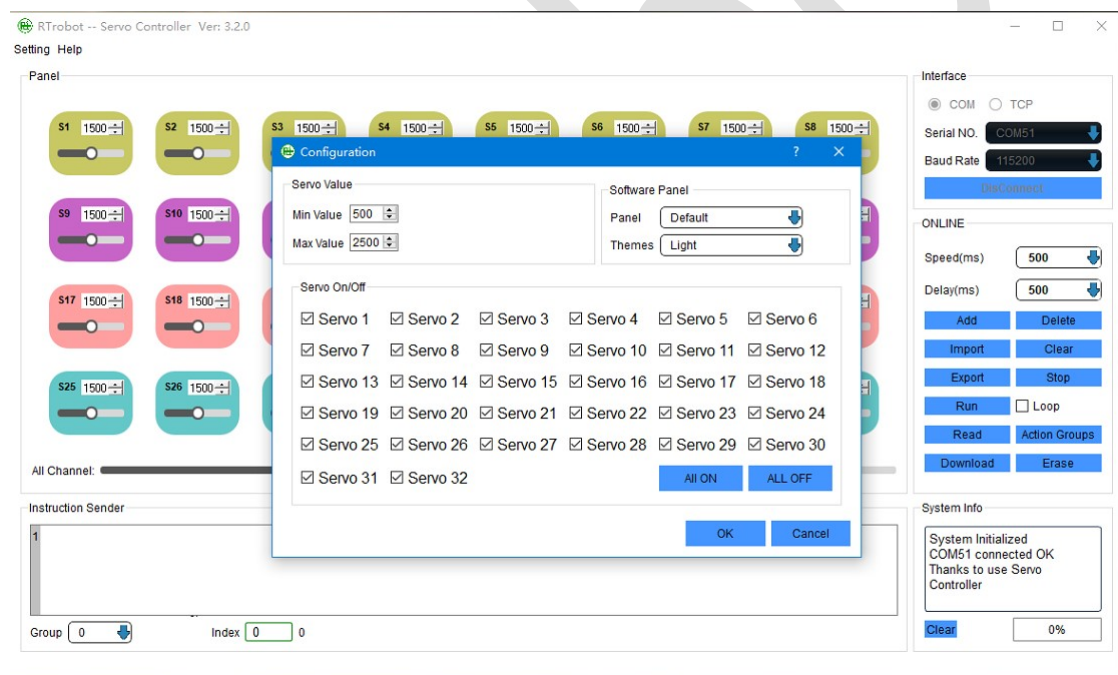

### **P.12**

Software Panel: After selection interface can specify each position servo motor serial number. like **P.13**.

**Note:** If there is a repeat of the servo motor serial number, can not be saved.



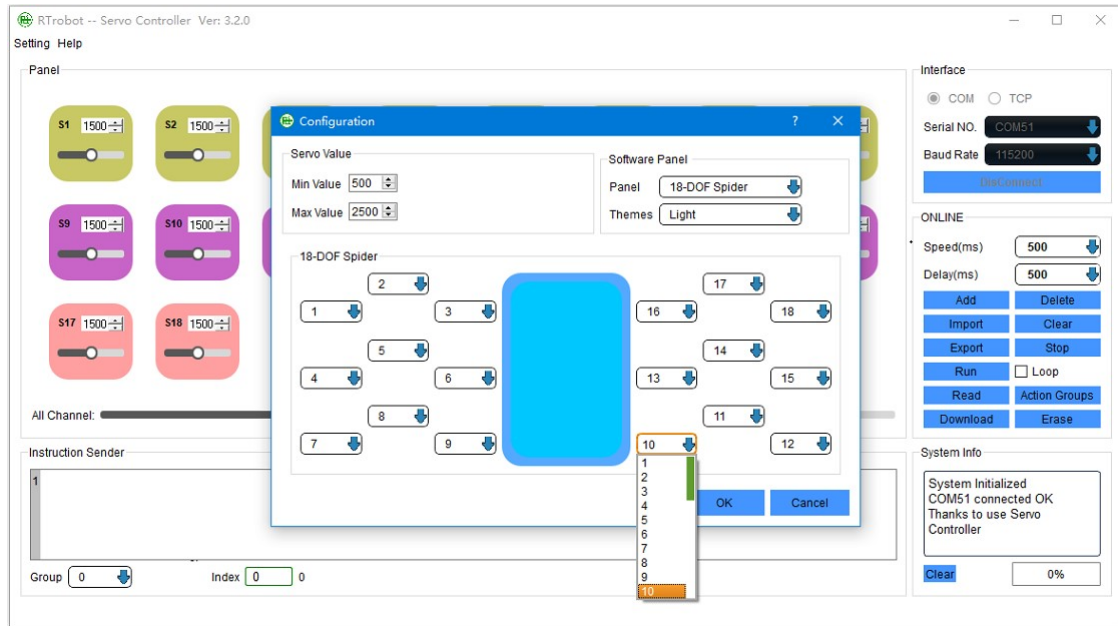

**P.13**

**II. Controller settings:**

Check "Setting" -> "Hardware" , You can set up the controller, like **P.14**(This option must link controller to display).

Servo initial value: Set the initial value of each servo motor start.

Servo Deviation Value: Set each deviation of servo motor(valid values: -99~99),like

**P.15.**

Uart Baud Rate: Set up **P.5** ④ the location of the serial port baud rate.

Buzzer: Low pressure alarm switch.

Start Automatic run: Turn on or off automatically run action group.

Automatic run group: Set up automatically run action group number, when the

"Start Automatic run" is set to "Only Group" mode, this option is invalid.

Automatic run times: Set up automatically run action group run times, when the

“Start Automatic run” is set to “Only Group” mode, this option is invalid.

Note: configure complete do not forget to click on the “Apply” , waiting for the settings to complete. Configured after the controller needs to restart will come into effect.

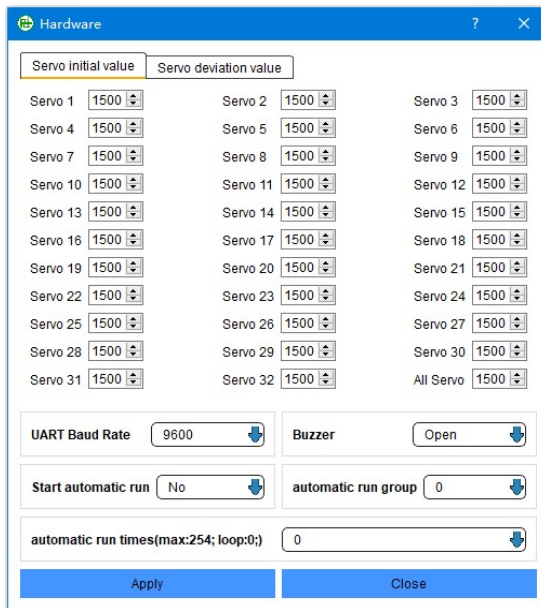

P.14

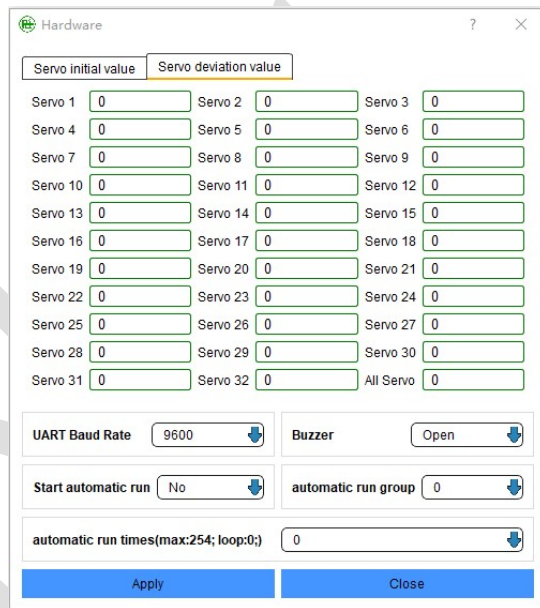

P.15

### III.3D Virtual:

Click "Setting" - > "3d Virtual" can display 3d Virtual.

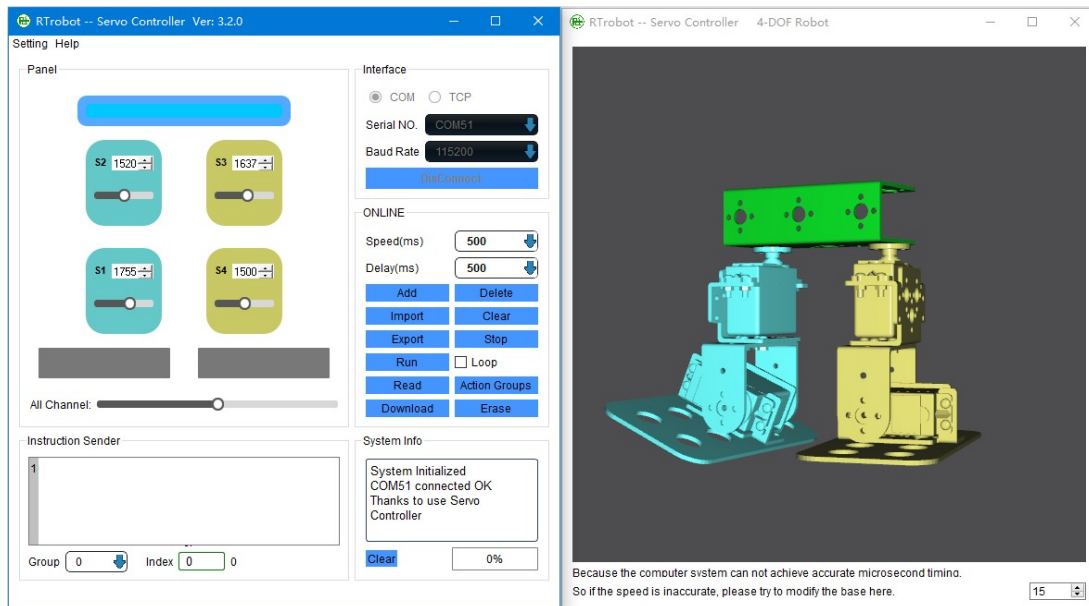

#### P.16

Note: Need to be in the "Software" Settings panel select control interface after open the serial port to display 3d interface.

### IV. Software control:

1. Select a suitable connection mode, and use the USB line to connect to the computer.

2. Installation controller driver (Servos Controller Drive.exe).

NOTE: If the warning does not have a digital certificate signature, drive installation fails. You need to put the computer "disable driver signature enforcement" approach to start the computer, run the driver installation again

3. Open the software "ServoController.exe" .

4. Select serial number, and open the serial. If used WIFI mode, choose the "TCP" ,

write the Server IP and Port.

**NOTE:** In order to use all of the features only USB link.

### ① Single servo motor operation:

like **P.17**, drag or fill can change servo motor angle values.



**P.17**

### ② Multiple servo motor operation:

Under the instruction information box "Group" checkbox to select good to edit action Group of serial number, configure each servo motor first run value, And then configure the running speed of servo motor and waiting time after the completion.

Check "Add" ,then configure each servo motor second run value, check "Add" .

All the preset run value were configure over, check "Run" to test.

running speed of servo motor: Finish the instruction at the specified time (not exceeding the maximum physical speed of the servo motor).

waiting time of servo motor: After completing the current instruction, delay the specified time, to perform the next instruction.



**P.18**

**③ Save instruction:**

Click on the "Export" keep the motion Instructions to the text, in order to import used next time.

**Note:** save the instruction for all action groups.

**④ Using the file import operation:**

Click on the "Import" save the past action in imported into the software.

Note: the import of all action group of instructions.

**⑤ Instructions edit:**

At the Instructions information box, click the line need to Edit the instructions in right select the "Edit" or "Ctrl+E" for editing

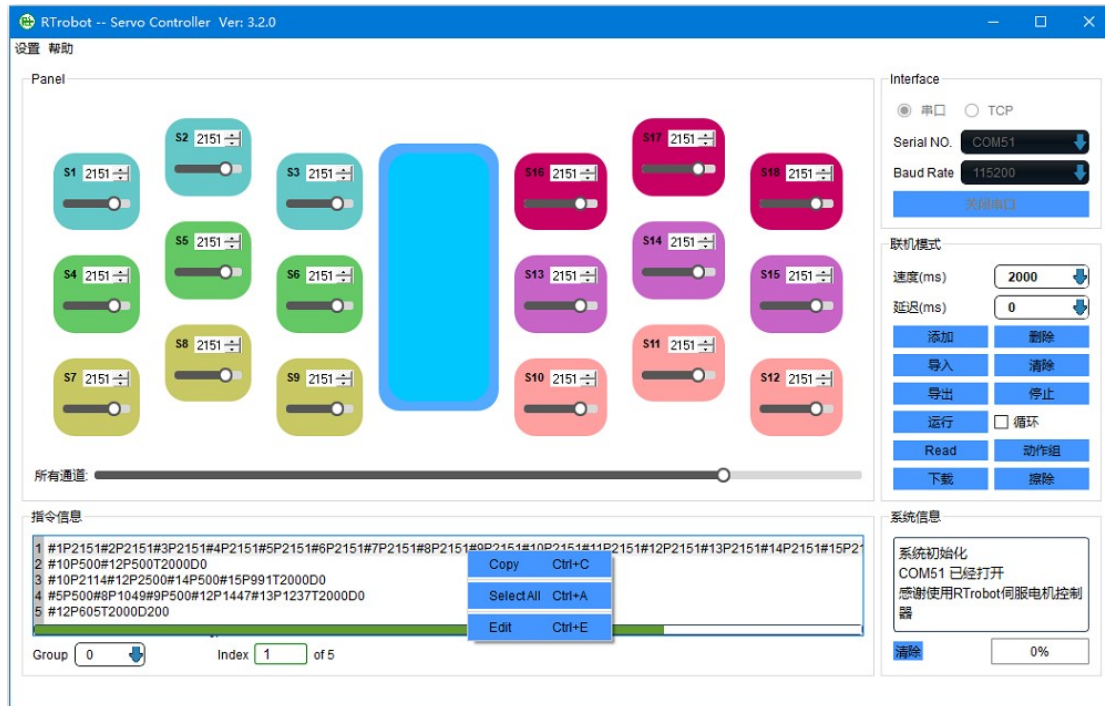

## P.19

### ⑥ Offline operate independently:

Staying all instructions to edit and then click the "Download" to Download all action group's instructions.

In the "Setting" - > "Hardware" open interface controller automatically switch and operation of action group number.

### ⑦ read the instructions:

Read all instructions have been downloaded to the controller.

### ⑧ Erase all action groups

Click "Erase" to erase all the action groups instructions, erase time is about 30 seconds.

## V. Pure action group instruction to edit:

Click "Action group" will appear action groups edit interface, like **P.20**.



G1: Action group 1

F3: run 3 times

After editing, can click "run" to test, if the test is correct, now you can download to controller board. At the next time you open the software, you can use the

"Read" to read previously downloaded action group instructions. if you want to auto run at start; click "Setting" -> "Hardware" , Change the "Start Automatic run" switch to "group only" .

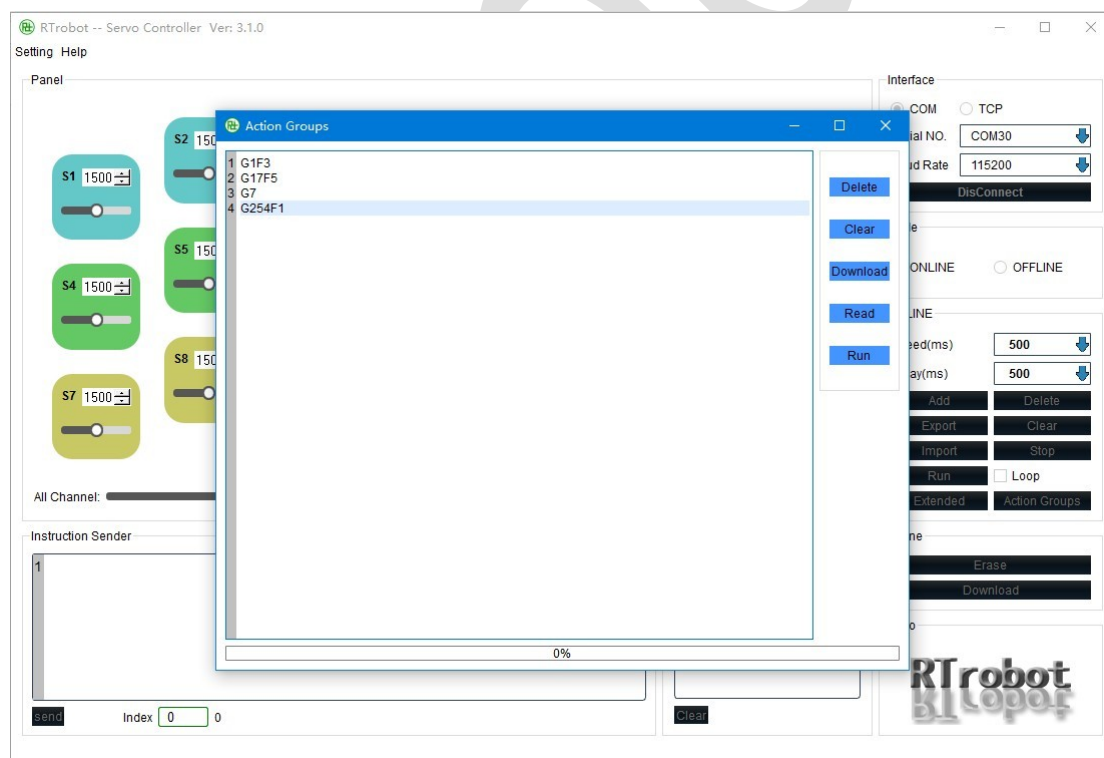

**P.20**



## VI. MPU6500(only 24 channels):

Click the "Setting" -> "MPU6500" to open the MPU6500 setup interface, like **P21**;

Click the "Disable" button to change the status to "Enable" to boot MPU6500.

Pitch、 Roll、 Yaw is value of MPU6500 XYZ; Fill in the allowable deviation value (no more than 90)、 out of range after the need to run the action group and the number of runs. After placing the controller in the final operating state and click the "Apply" button to enable it and restart the controller board. When the controller is tilted in any direction other than the set run value, the previously set action group and run count will triggered. (If you use the USB line to connect the computer and use the PC software debug,mpu6500 will not trigger.)

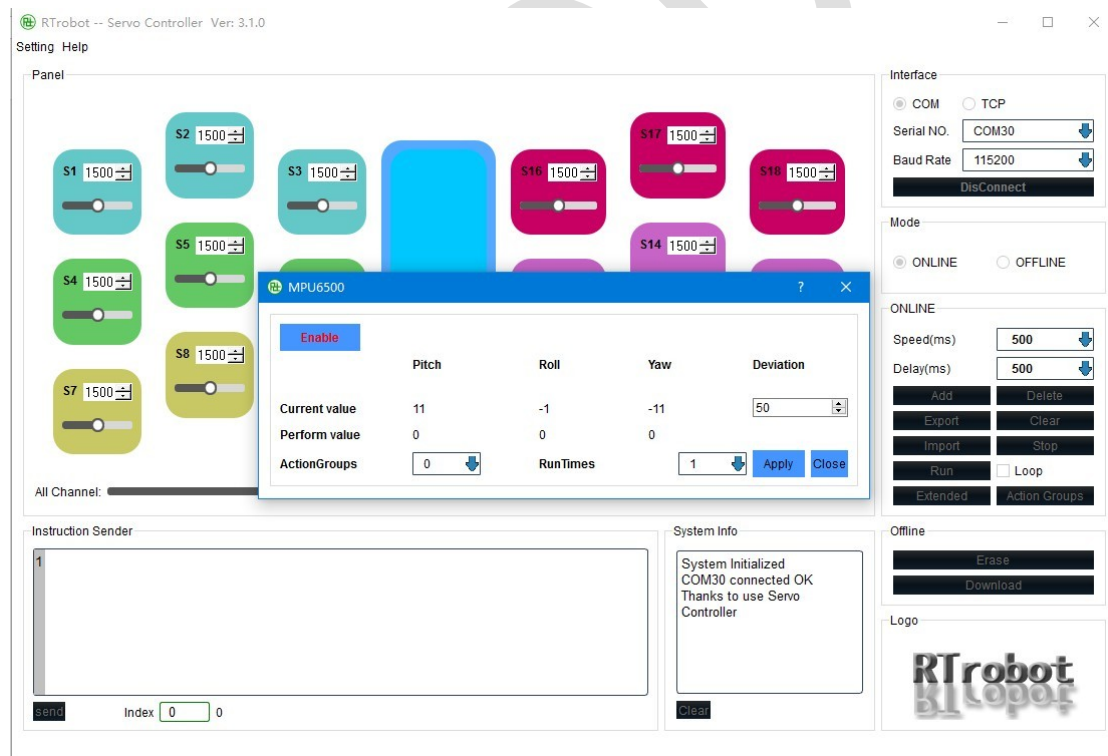

### P.21

**Note:** before performing the action group, the serial port will first feedback "TRIGGER".

After the completion of the specified action group feedback "OK".



## VII. 6 channel digital level sensors (only 16 channels):

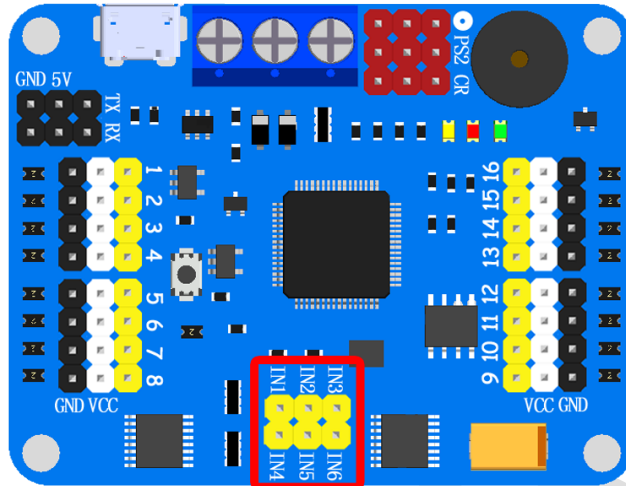

**P.22**

The red circle section can be connected to 6 channel digital level sensors, each sensor can independently control 6 action groups or maintain the current position of the specified servo motor (**Only support 3.3/5 v digital level sensor**).

If you use the USB line to connect the computer and use the PC software debug, external sensors will not trigger.

**Note:** the GND of each digital level sensor needs to be connected to the GND of the servo controller.

When multiple "IN" is triggered at the same time, the smaller number of "IN" is valid.

**IN1>IN2>IN3>IN4>IN5>IN6**

Example1: IN2 and IN3 trigger at the same time, it will only perform IN2 specified action group, if IN2 release, IN3 trigger, execute IN3 specified action group.

Example2: After the IN1 is triggered, the action group is started, and the IN6 is used to keep the current position of the servo motor. When both of them are triggered, the IN1 and the IN6 are both effective.

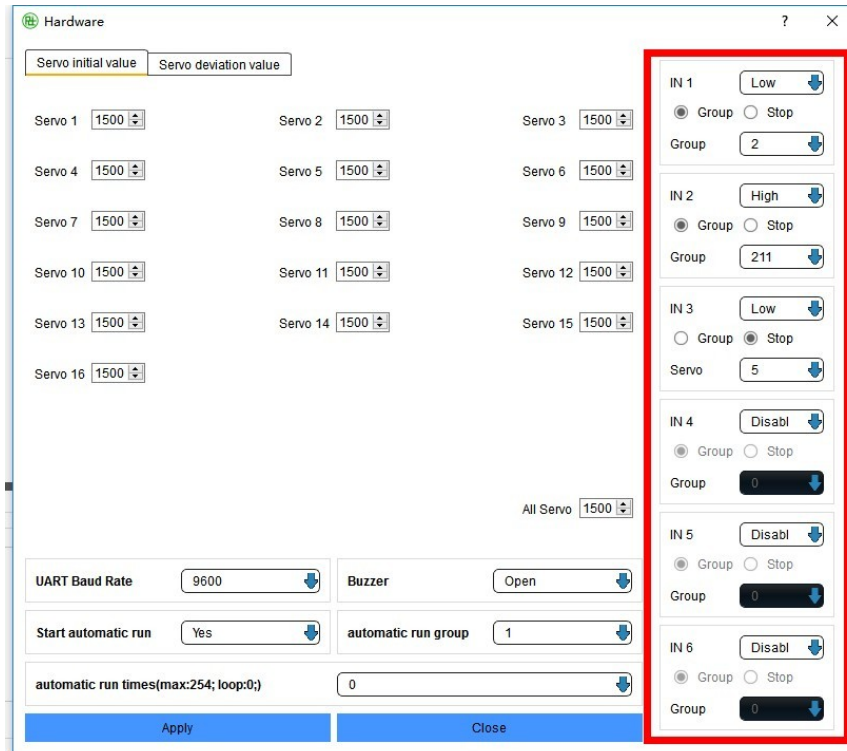

P.23

INx Three options:

- Disable: Disable (Trigger is invalid)
- High: High level trigger
- Low: Low level trigger

Group: Trigger the action group to be executed.

Stop: After the trigger the servo motor stops and remains the current position.

**Note:** Before performing the action group, the serial port will first feedback "TRIGGER".

After the completion of the specified action group feedback "OK".

**Note:** Invalid AC level sensor.

**VIII.**

1. On "<http://www.rrobot.org/software/>" website to download the latest PC software
2. Open the latest PC software
3. Press and hold the key on the servo motor controller to release the USB cable after releasing the key.

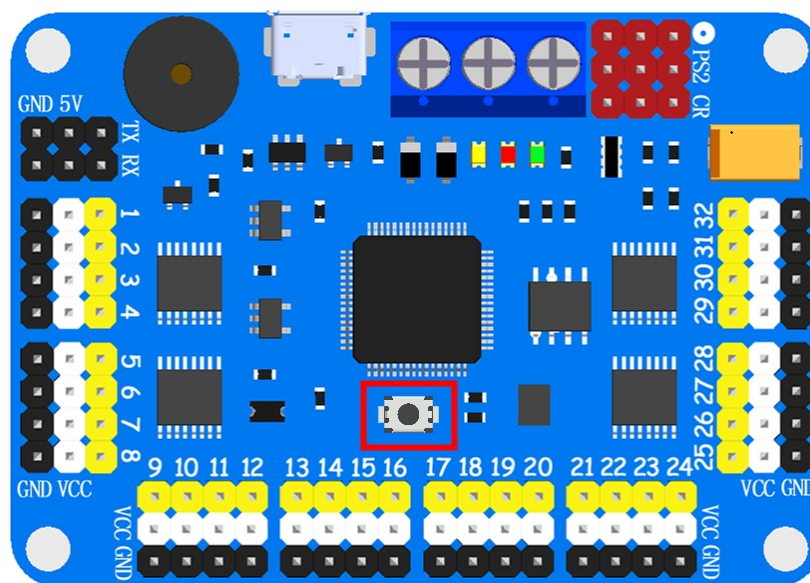
**P.24**

4. Open the latest PC software serial port, then the firmware began to upgrade, after the upgrade will be mentioned "Update Success, Restart the controller, Please."
5. Restart the servo motor controller
6. If is the latest firmware will prompt "ERROR Don 't need UPdate!"

**Size chart:**

**32 channels:**

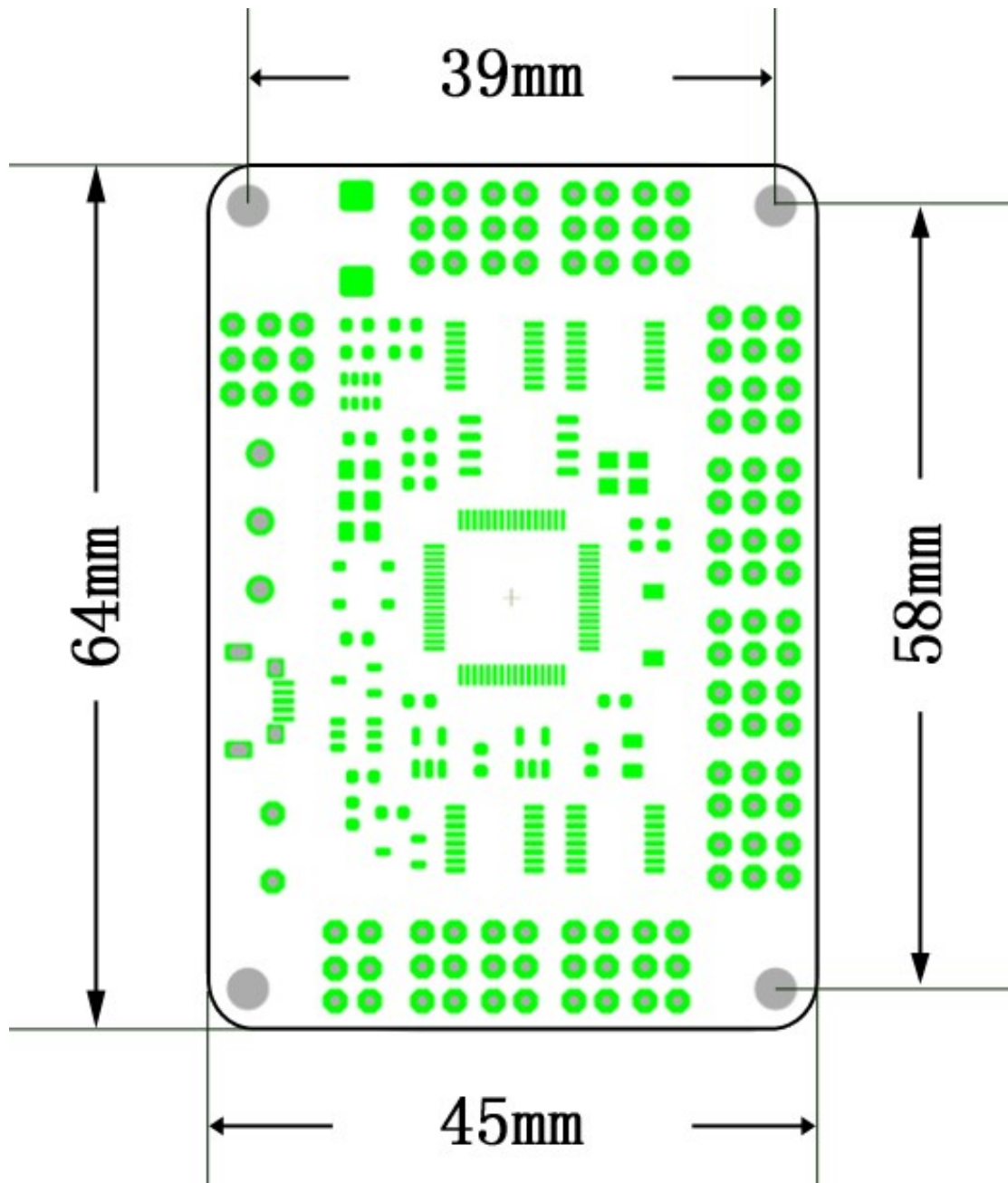

**24 channels:**

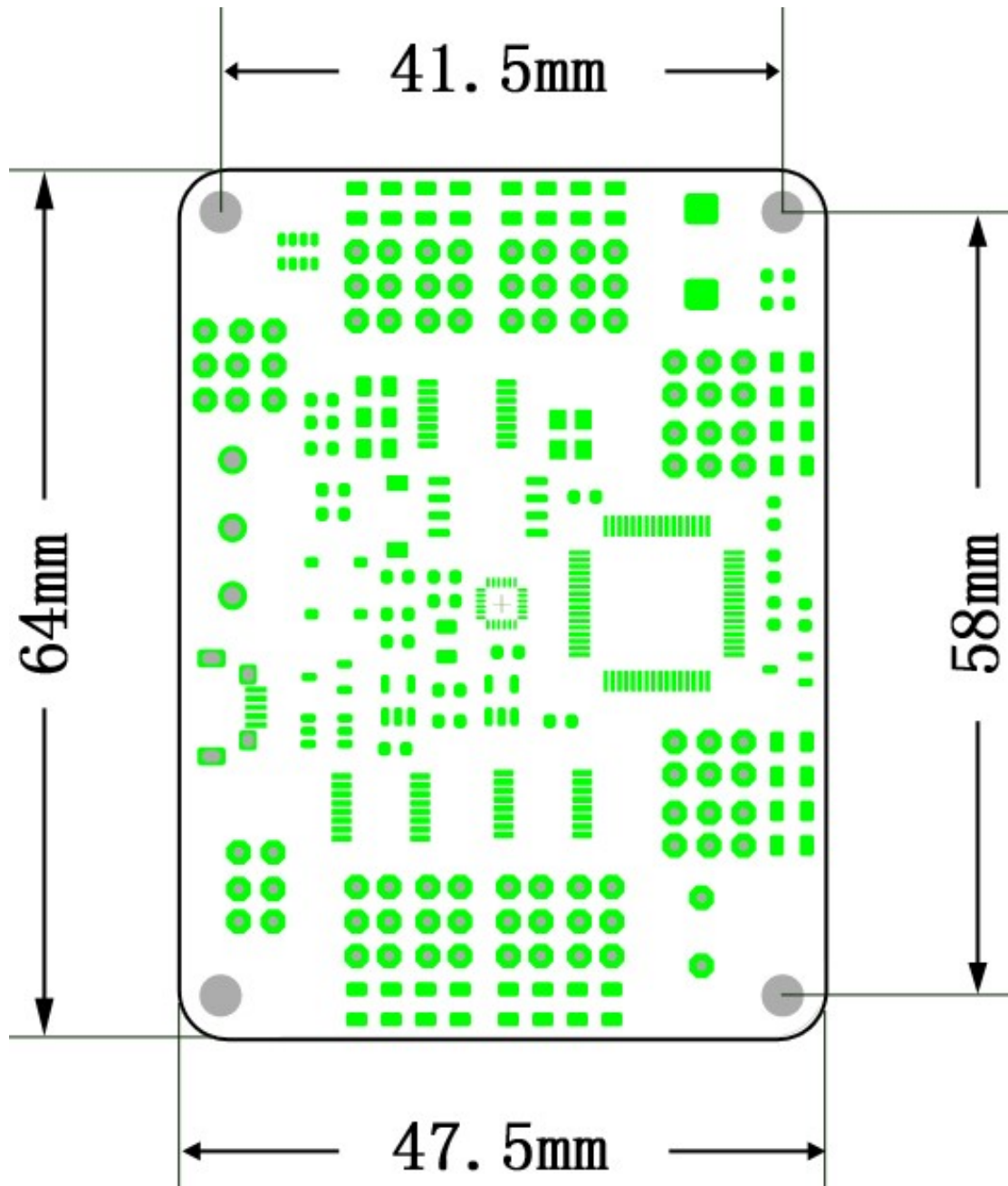

**16 channels:**

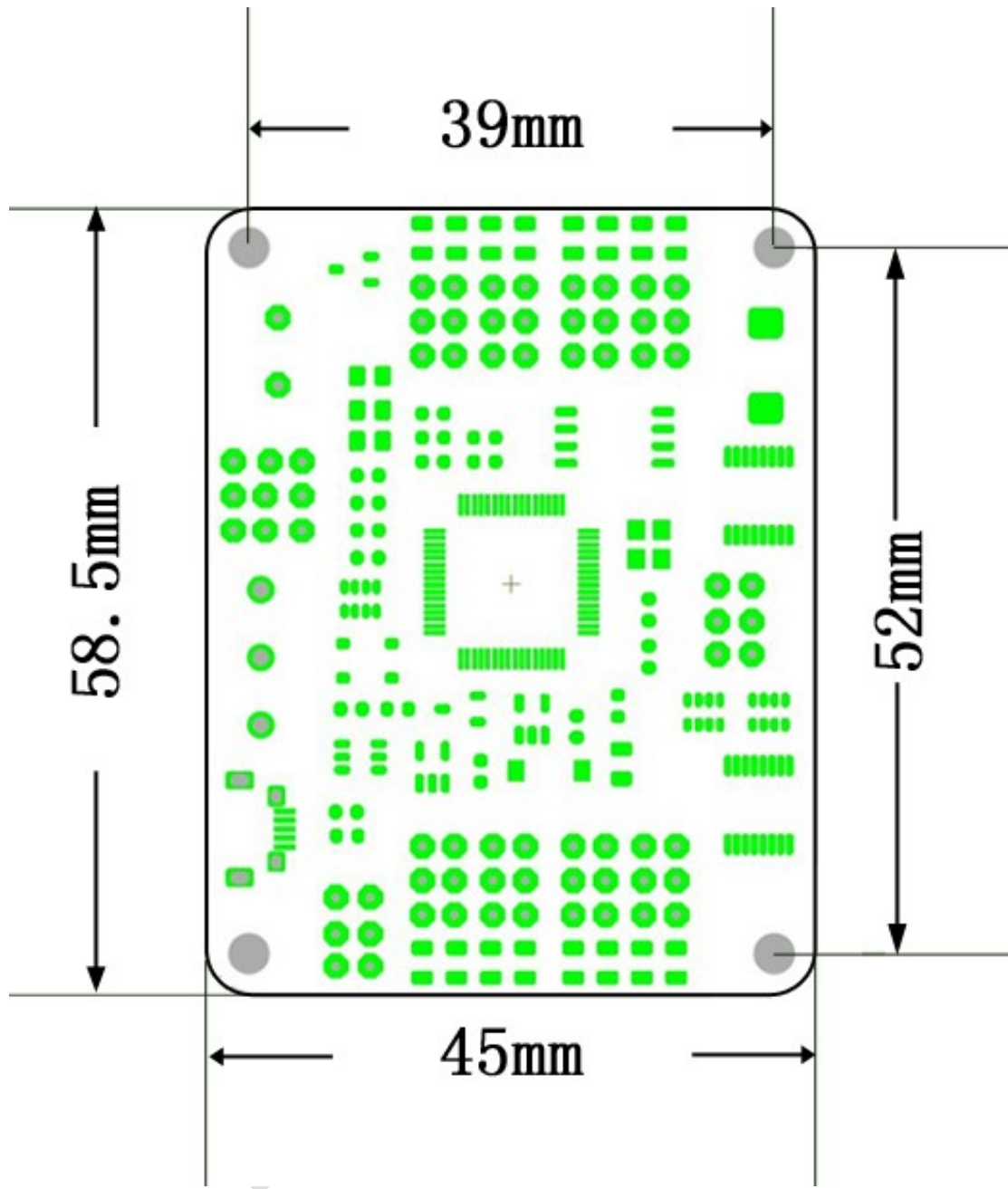

**IX. About:**

Thank you for using RRobot of servo motor controller, have any questions about the controller in use need to consult to mail : [admin@rrobot.org](mailto:admin@rrobot.org)