

LX-16A Bus Servo User Manual



Overview

LX-16A serial bus intelligent servo is the integrated servo which is a set of motor, servo drive, serial bus communication interface and sensor, it is mainly used for micro-robot joints, wheels, crawler drive, it can also be used for other simple control occasions.

Product Parameters:

Net weight	52 g(1.8oz)
Product size	1.78in*0.97in*1.38in
Rotation speed	0.18sec/60degree(6v) 0.16sec/60degree(7.4v)
Servo accuracy	0.24°
Torque	15kg.cm/208oz.in(6V); 17kg.cm/236oz.in(7.4)
Servo ID	0~253(user setting)
Storage users' parameter setting after power off	support
Length of servo wire	20cm
Read back function	support
Control method	Serial command
Communication baud rate	115200
Gear type	metal
Parameter feedback	temperature/voltage/position
Apply to	all kinds of Bionic robot joints

Catalog

Catalog.....	3
Main function introduction.....	4
Structure diagram.....	5
TTL/USB Debug Board.....	6
1. Brief introduction.....	6
2. Install driver.....	6
3. The introduction of the debug board.....	7
4. Connection diagram.....	8
Bus Servo Debug System.....	9
1. Brief introduction.....	9
2. Installation.....	9
3. Function introduction.....	10
4. Parameter setting.....	12
Appendix: Part of communication protocol.....	14
Technical Support.....	15

Main function introduction

1. Serial bus interface:

The control board use a I/O port to connect the serial servo, high precision gears are mosaic with each other, which reduces the noise caused by gear friction. This can reduce the occupation of the serial port. Simple wiring make product more simple, exquisite, attractive.

2.ID number set

Each servo can set the ID number for the identification of the servo. The servo ID defaults to 1 and can be modified by yourself. The controller communicates with the servo in a single bus mode and the communication baud rate is 115200. The user can assign an ID number to each servo, and the command from the controller contains the ID information. Only the servos that match the ID number can receive this instruction and follow the instructions to execute the action.

3.High-precision potentiometer

The interior of the servo is imported with high precision potentiometer as an angle feedback. The accuracy and linearity of the servo are good, making the robot run more stable. The life expectancy of the servo is also significantly increased.

4.Read angle

LX-16A servo has the function of angle feedback, support angle read back, you can quickly read the servo angle to capture the position of the robot joint. Greatly facilitate the robot action design, the surface of the servo has scale line, easy to adjust the angle of the servo.

5.Temperature, voltage feedback

With temperature feedback and voltage feedback, controller can gain the internal data of the servo in real time to protect it. The top of the servo has a warning light, and the indicator will flash if the internal of servo is abnormal.

6.Two working modes

- (1)The servo can be controlled within the range of 240 degrees in the servo mode
- (2)The servo can be rotated continuously for 360 degrees, you can control the direction and speed of rotation.

7.Compact design

Relative to other bus servo on the market, LX-16A with short shell and short body design. The compact structure makes the designed robot more exquisite and makes the robot products more bionic.

8.Double ball bearing

The Joint parts of the Humanoid robot need to combine the bracket and metal driving

ball bearing and assistant ball bearing, powered by the servo to drive the rotation of the bracket, so that the robot joint can move steadily.

9.Metal gear

The high-speed output of the Internal DC motor , obtain a greater torque through the 5-stage reduction ratio. And high-precision gear insert reduces the noise caused by gear friction.

Structure diagram

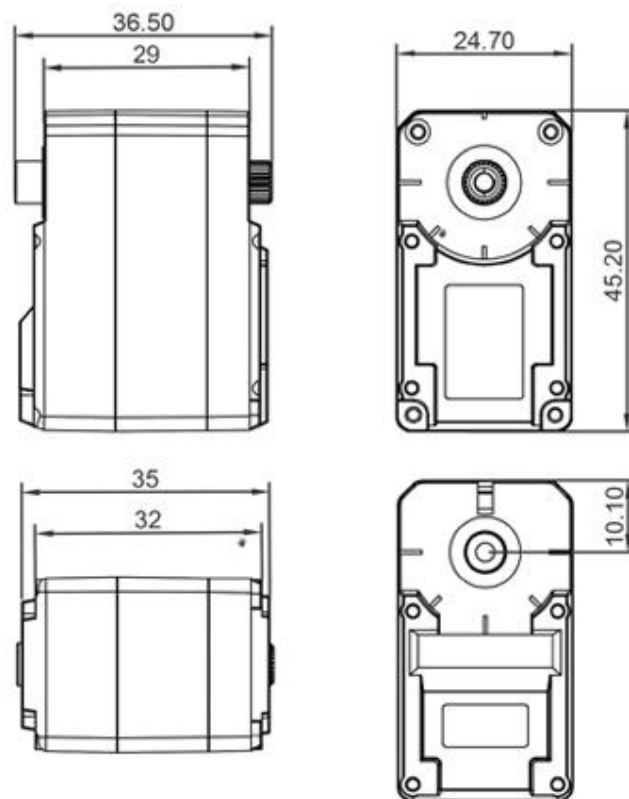

Unit: mm

TTL/USB Debug Board

1. Brief introduction

Because the bus servo is using our private protocol, so you need to connect our debug board to control bus servo no matter what single chip you are using(we provide communication protocol).

No matter how many bus servos you need to control, all you need to use is a debug board.

The use of the debug board requires the debug software (please refer to the "Debugging Software" section)

2. Install driver

You need to install the driver before using debug board.

Double click the icon  ch341ser, The interface is shown below



Click "install", the following interface appears after waiting for a few seconds



It means the installation is successful, debug board can be used normally.

3. The introduction of the debug board

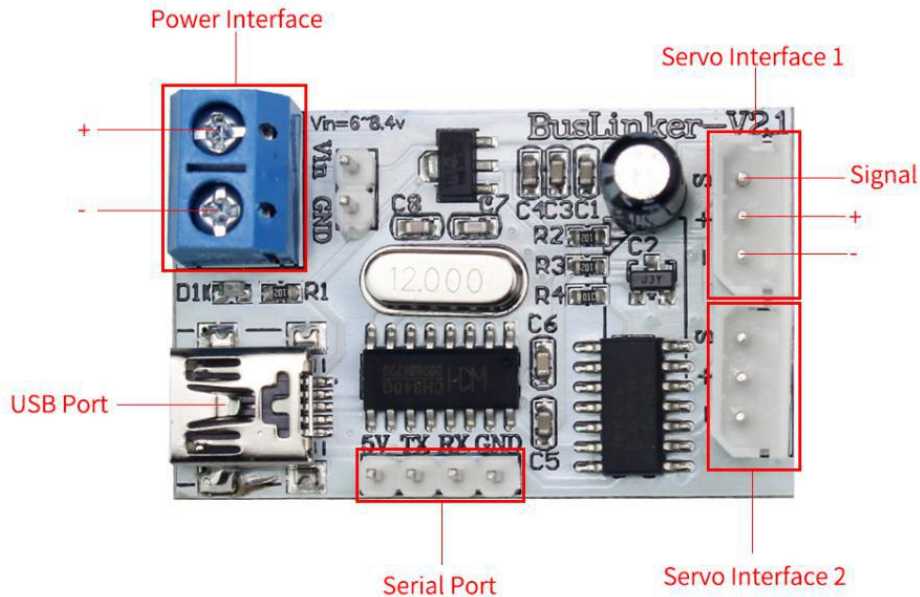

When the debug board is connected to the power supply, you can directly connect to the computer with the USB cable. You can test servo and set the servo parameters through our PC software.

You can control servo and read the angle of the servo with the debug board by connecting to the TXD and RXD of the single chip .

(LX-16A servo has three wires, positive, negative and signal wire respectively. This signal wire can receive and send data at the same time. It's too much trouble If we want to use the single chip to control the bus servo. So we offer you this BusLinker debug board which can convert the serial port of the servo into a two - wire serial port. It is easy for you to control bus servo with single chip.

4.Connection diagram

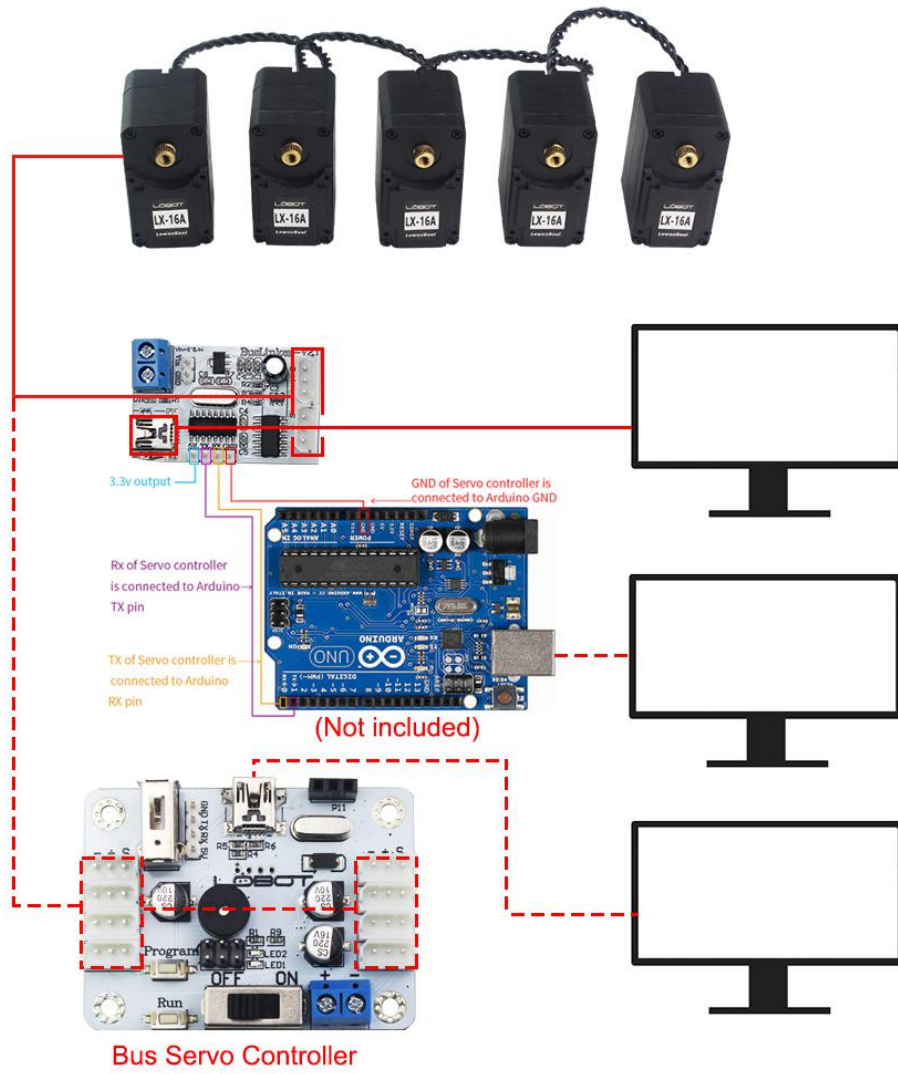

Bus Servo Debug System

1. Brief introduction

You can set the ID number, working modes, rotation speed, rotation range, the state of the LED lights (off/on), you can also set the over temperature alarm, over voltage alarm and stall alarm for bus servo.

Setting ID number is the necessary step before using each servo. In other words, we can use bus servo normally only after setting up ID number for bus servo.

2. Installation

Double click the icon  Bus Servo Terminal , the interface is shown below

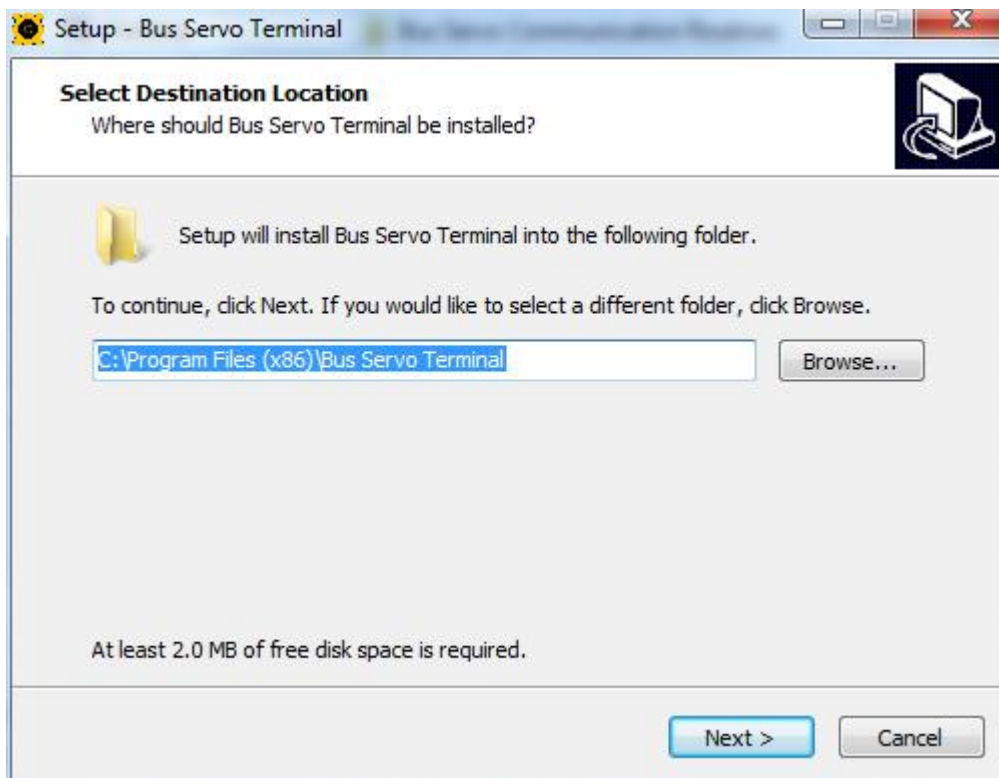

(1, You need to install dotNetFx40_Client_x86_x64.exe , if the operating system is windows XP . If it has installed, please ignore it.

2, If you still cannot open, please press right mouse button and then "run as administrator")

Follow the prompts to complete the installation step by step, main interface as shown below after the successful installation .

3. Function introduction



Main Interface

Basic operation interface

1.



After you connect to the computer, select "COM3" (COM3 will appear when the connection is normal), the baud rate is the default value, and then click "Open Port", the left indicator light turns green, indicating the connection is successful (The blue light on the top of the bus servo will always light, indicating everything is normal).

2.

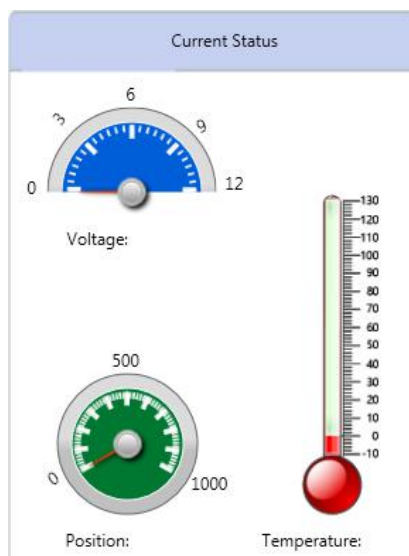

The right interface of this window shows the current position and temperature of the servo and the battery voltage.

3.

Fill in the ID of the servo you want to control, the default value is 1, range 0 ~ 253, you can only control one servo at the same time.

4.

Two modes: servo mode and motor mode
 In Servo Mode,
 Position: you can drag the slider to make servo rotates ,the faster you drag, the faster the servo rotates
 Time:set the rotation time of the servo, the greater the time value, the slower the rotation of the servo

In Motor Mode:

Drag the slider to change the speed value.
 When the speed value is 0, the servo is in a stopped state.
 When the speed is positive, the servo turn counterclockwise, the greater the speed value, the faster the rotation speed.
 When the speed is negative, the servo turn clockwise , the smaller the speed value ,the faster the rotation speed.

5.



On/Off the power supply of motor.

4. Parameter setting

Switch to the “Parameter” interface by clicking the Parameter icon.

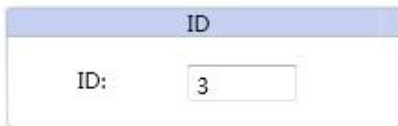

Sets the ID number for the currently controlled servo



Adjust servo deviation

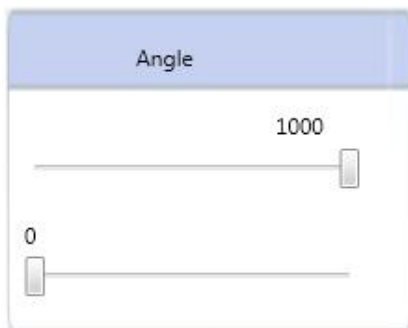

The default value of the servo rotation range is 0 to 240 degrees. Changing this value allows you to adjust the rotation range of the servo. For example: if you drag the slider to 500 value and don't change the drag the slider located below, the servo rotation range becomes to 0 ~ 120 degrees.



Select whether to turn on the LED

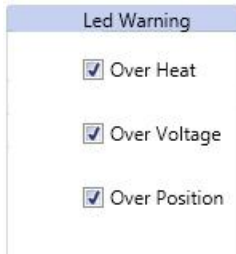

When the servo is running normally, the blue light is on and the blue light flashes when over heat, over voltage or locked-rotor occurs. Tick to determine whether the light will alarm the selected status.

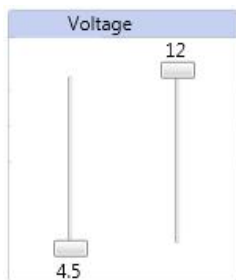

Set the voltage alarm range, the light will flash to alarm when the battery voltage is not within the setting voltage range.

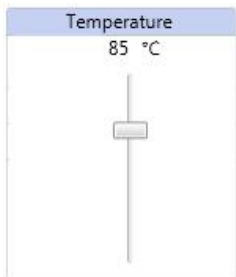

Setting the upper limit of the temperature alarm, and the light will flash to alarm when the servo temperature exceeds the setting range.

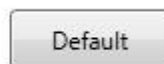
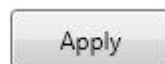
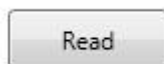

Read: Reads the parameter settings of the currently controlled servo

Apply: After changing the parameter value, you need to click the Apply button to take effect

Default: Returns to the default

Appendix: Part of communication protocol

UART Interface schematic diagram

Servo uses the program code to carry on the timing control to the UART asynchronous serial interface, realizes the half-work asynchronous serial bus communication, the communication baud rate is 115200bps, and the interface is simple, the protocol is simplified. In your own designed controller, the UART interface for communication with the servo must be handled as shown below.

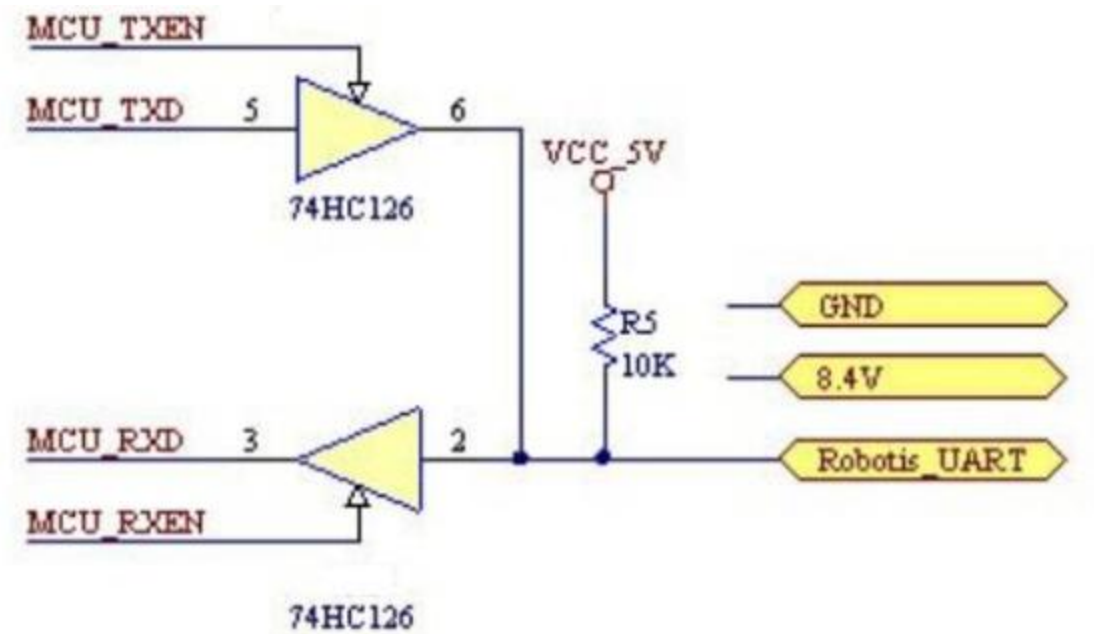

Please download protocol pdf to get whole communication protocol.

Technical Support

If there is anything that you do not understand, please check the instructions or the accompanying video tutorial, if the problem still can not be solved, please feel free to contact us by email at support@lewansoul.com

Please visit the following link or scan the QR codes to get related instructions and video tutorial.

	Get instructions(Dropbox)	Get video tutorial(Youtube)
Link	http://bit.ly/2rJshh6	http://bit.ly/2t4MNwS
QR code		