



SPECIFICATION

Product Model: YX-1024100T104N002B-T

DESIGNED	CHECKED	Approved
		

Approval by Customer:

Ok

NG, Problem survey

Approved By _____

Table of Contents

List	Description	Page No.
	Cover	1
	Revision Record	2
	Table of Contents	3
1	Scope	4
2	General Information	4
3	External Dimensions	5
4	Interface Description	6
5	Absolute Maximum Ratings	6
6	DC Characteristics	6
7	Timing Characteristics	7
8	Backlight Characteristics	11
9	Optical Characteristics	12
10	Reliability Test Conditions and Methods	13
11	Inspection Standard	15
12	Handling Precautions	20
13	Precaution for Use	21
14	Packing Method	21

1. Scope

This specification defines general provisions as well as inspection standards for TFT module supplied by YUXIANG electronics.

If the event of unforeseen problem or unspecified items may occur, naturally shall negotiate and agree to solution

2. General Information

ITEM	STANDARD VALUES	UNITS
LCD type	10.4" TFT	--
Dot arrangement	1024×3 (RGB)×100	dots
Color filter array	RGB vertical stripe	--
Display mode	Normally White	--
Viewing Direction	ALL(80/80/80/80)	--
Gray Viewing Direction	ALL(80/80/80/80)	--
Module size	274.92(W)×41.5(H)×3.5(T)	mm
Active area	264.192(W)×25.8(H)	mm
Dot pitch	0.258(W)×0.258(H)	mm
Interface	TTL	--
Operating temperature	-20 ~ +70	°C
Storage temperature	-30 ~ +80	°C
Module Weight	TBD	g

3. External Dimensions

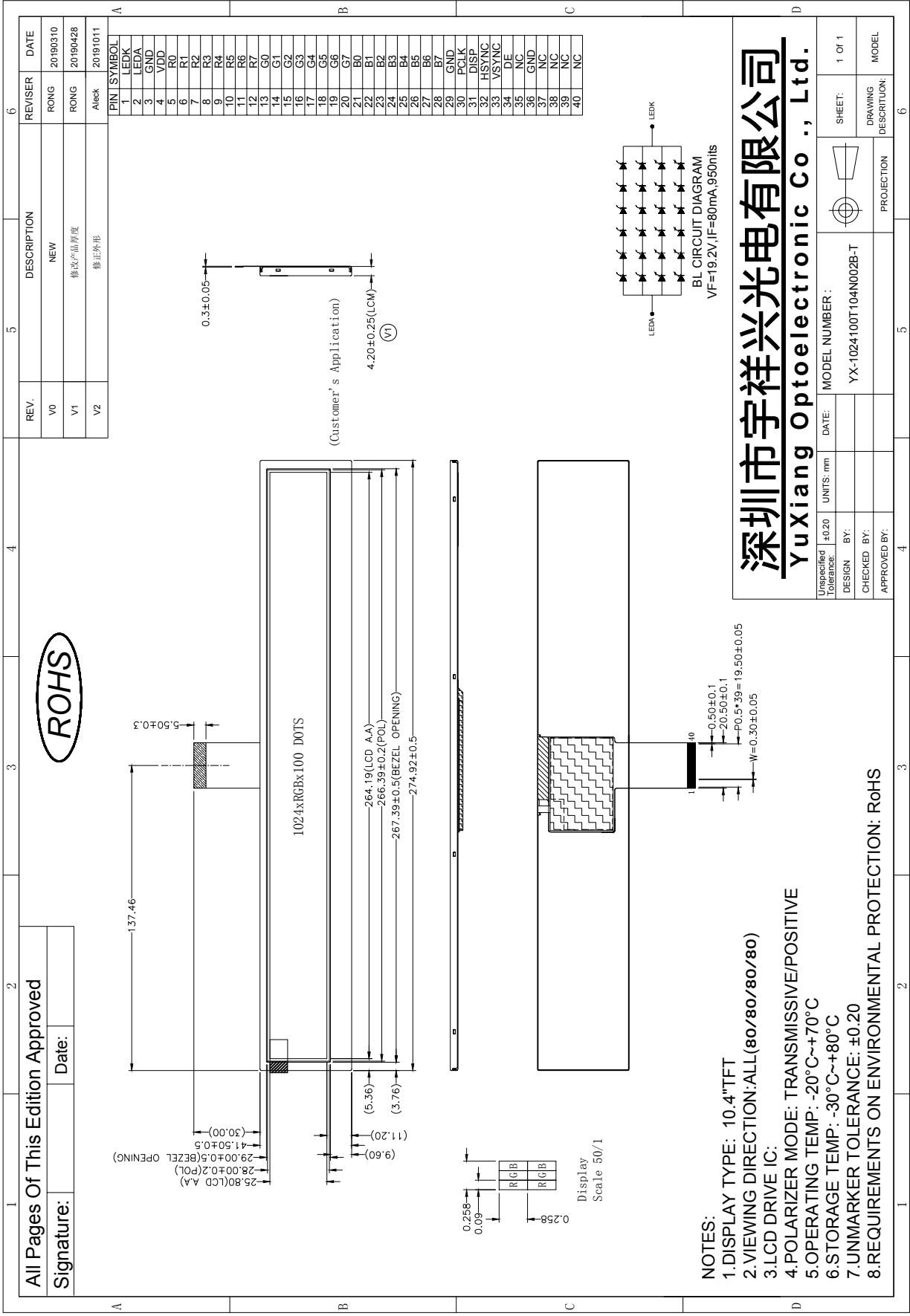

4. Interface Description

PIN NO.	PIN NAME	DESCRIPTION
1	LEDK	LED backlight (Cathode).
2	LEDA	LED backlight (Anode).
3	GND	Ground.
4	VDD	Power supply.
5~12	R0~R7	Red Data
13~20	G0~G7	Green Data
21~28	B0~B7	Blue Data
29	GND	Ground.
30	DCLK	Clock
31	DISP	Display on/off
32	HSYNC	Horizontal sync input in RGB mode.
33	VSYNC	Vertical sync input in RGB mode.
34	DE	Data enable input. Active high to enable the input data bus.
35	NC	No connection
36	GND	Ground.
37~40	NC	No connection.

5. Absolute Maximum Ratings

Item	Symbol	Min.	Max.	Unit
Digital Supply Voltage	DVDD	-0.3	3.6	V
Operating Temperature	T _{OP}	-20	70	°C
Storage Temperature	T _{ST}	-30	80	°C
Storage Humidity	HD	20	90	%RH

6. DC Characteristics

Item	Symbol	Min.	Typ.	Max.	Unit	Remark
Digital Supply Voltage	DVDD	3.0	3.3	3.6	V	-
Logic Input Voltage	V _{IH}	0.7DVDD	-	DVDD	V	-
	V _{IL}	GND	-	0.3DVDD	V	-
Supply Current	DVDD		150	280	mA	

7. Timing Characteristics

7.1 Power Sequence

a. Power on:

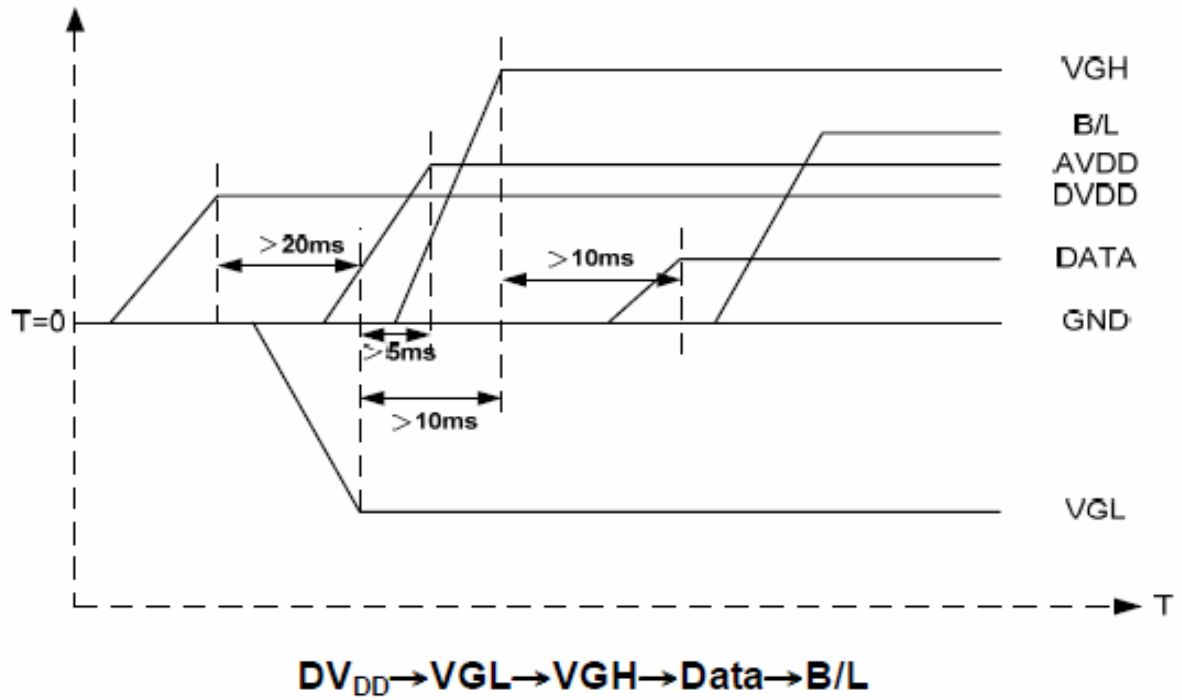

b. Power off:

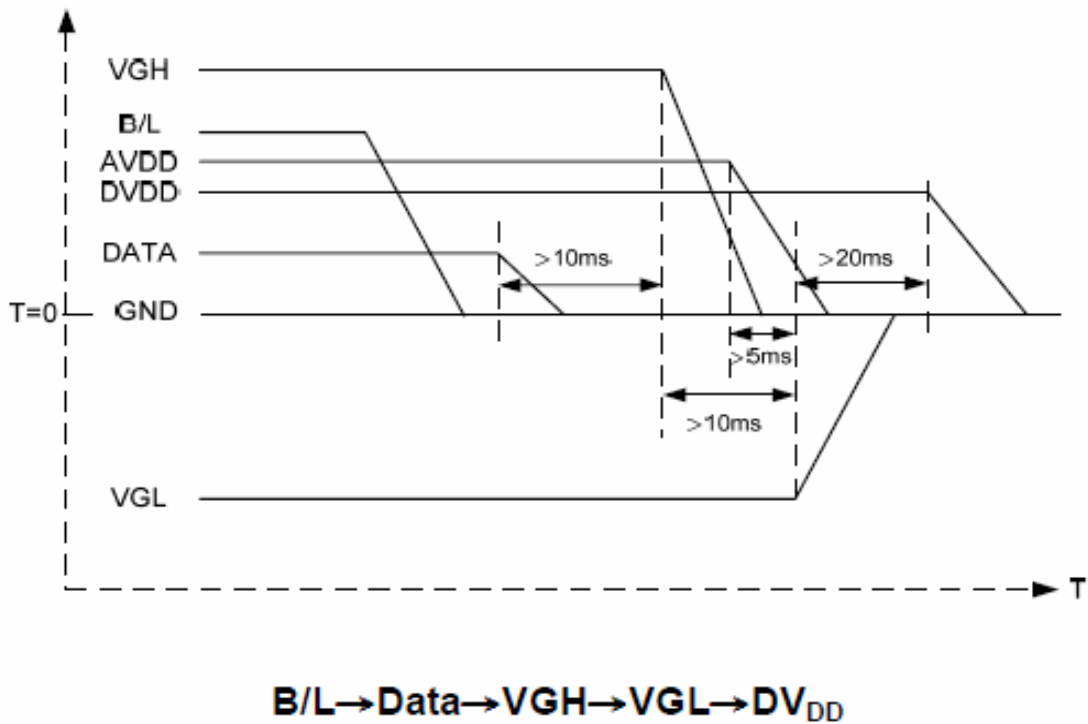

Note: Data include R0~R7, B0~B7, GO~G7, U/D, L/R, DCLK, HS, VS, DE.

7.2 AC Electrical Characteristics

Item	Symbol	Values			Unit	Remark
		Min.	Typ.	Max.		
HS setup time	T_{hst}	8	-	-	ns	
HS hold time	T_{hhd}	8	-	-	ns	
VS setup time	T_{vst}	8	-	-	ns	
VS hold time	T_{vhd}	8	-	-	ns	
Data setup time	T_{dsu}	8	-	-	ns	
Data hole time	T_{dhd}	8	-	-	ns	
DE setup time	T_{esu}	8	-	-	ns	
DE hole time	T_{ehd}	8	-	-	ns	
DV _{DD} Power On Slew rate	T_{POR}	-	-	20	ms	From 0 to 90% DV _{DD}
RESET pulse width	T_{Rst}	1	-	-	ms	
DCLK cycle time	T_{coh}	20	-	-	ns	
DCLK pulse duty	T_{cwh}	40	50	60	%	

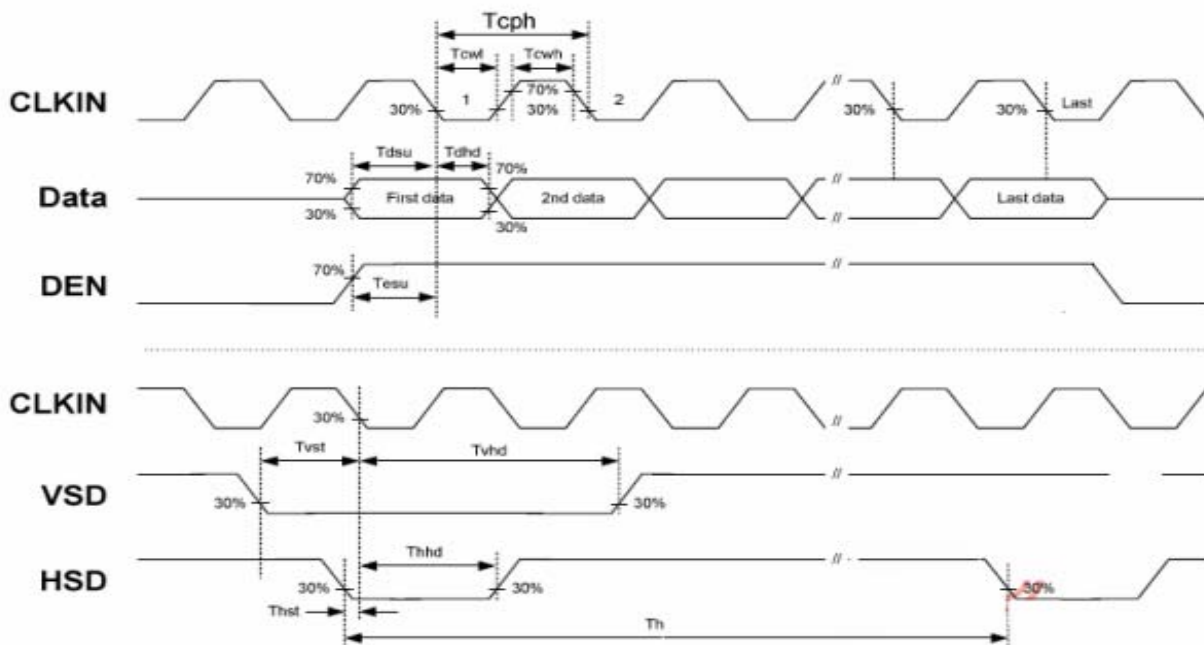

7.3 Data Input Format

Horizontal input timing diagram



Vertical input timing diagram

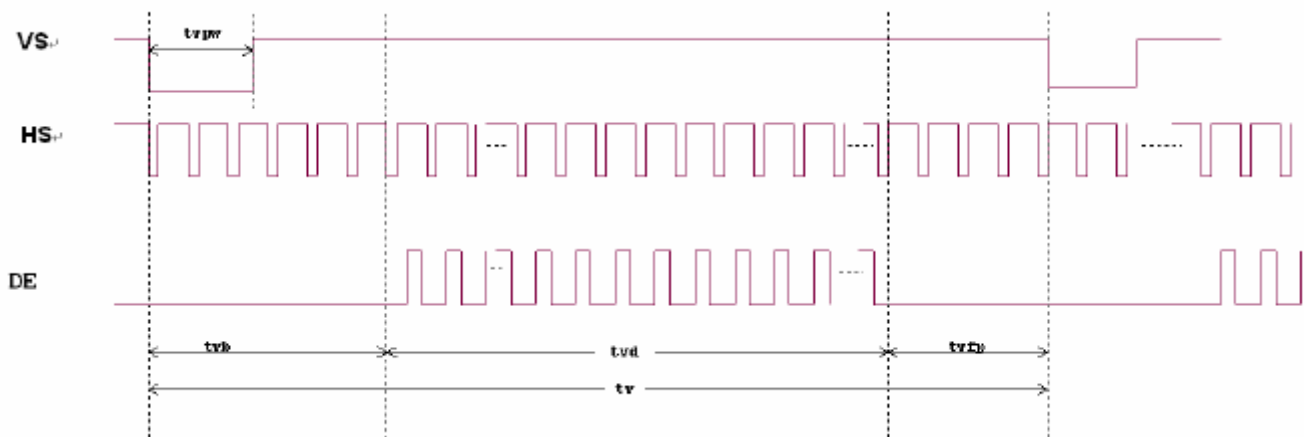

7.4 Timing

DCLK latch => Falling latch



(UD=H, LR=H) 正掃(左上到右下)

Timing Table HX8282A			SYNC MODE		
Parameter	Symbol	Value			Unit
		Min.	Typ.	Max.	
Frame Rate	-		60.2		Hz
DCLK Frequency	F _{DCLK}		21		MHz
Horizontal	Total line	t _H		1344	DCLK
	Active pixels	t _{Hact}		1024	DCLK
	Back porch	t _{HBP}		159	DCLK
	Pulse width	t _{HSP}		1	DCLK
	Front porch	t _{HFP}		161	DCLK
Vertical	Total time	t _V		258	H
	Active lines	t _{Vact}		100	H
	Back porch	t _{VBP}		21	H
	Pulse width	t _{VSP}		2	H
	Front porch	t _{VFP}		135	H

Note : Back porch is NOT included pulse width



(UD=L, LR=L) 反掃(右下到左上)

Timing Table HX8282A			SYNC MODE		
Parameter	Symbol	Value			Unit
		Min.	Typ.	Max.	
Frame Rate	-		60.2		Hz
DCLK Frequency	F _{DCLK}		21		MHz
Horizontal	Total line	t _H		1344	DCLK
	Active pixels	t _{Hact}		1024	DCLK
	Back porch	t _{HBP}		159	DCLK
	Pulse width	t _{HSP}		1	DCLK
	Front porch	t _{HFP}		161	DCLK
Vertical	Total time	t _V		259	H
	Active lines	t _{Vact}		100	H
	Back porch	t _{VBP}		57	H
	Pulse width	t _{VSP}		2	H
	Front porch	t _{VFP}		100	H

Note : Back porch is NOT included pulse width

8. Backlight Characteristics

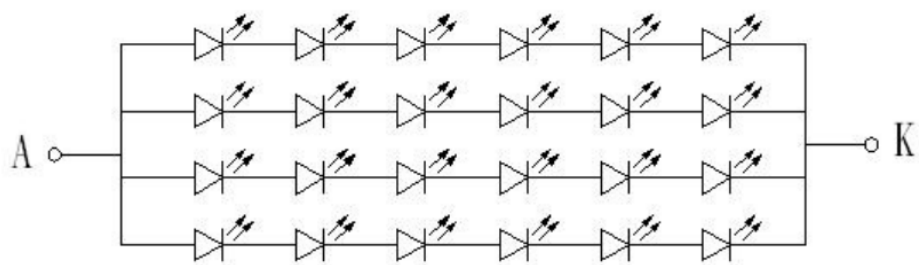

LED 電路圖

Item	Symbol	MIN	TYP	MAX	UNIT	Test Condition
Supply Voltage	Vf	17	19.2	21.6	V	If=80mA
Supply Current	If	-	80	-	mA	If=80mA
Luminous Intensity for LCM	-	800	950	-	cd/m ²	If=80mA
Uniformity for LCM	-	80	-	-	%	If=80mA
Life Time	-	-	50000	-	Hr	If=80mA

9. Optical Characteristics

Item	Conditions	Min.	Typ.	Max.	Unit	Note	
Viewing Angle (CR>10)	Horizontal	θ_L	-	80	-	degree	(1),(2),(6)
		θ_R	-	80	-		
	Vertical	θ_T	-	80	-		
		θ_B	-	80	-		
Contrast Ratio	Center	-	300	-	-	(1),(3),(6)	
Response Time	Rising + Falling	-	25	-	ms	(1),(4),(6)	
CF Color Chromaticity (CIE1931)	Red x	Typ. -0.05	-	Typ. +0.05	-	(1), (6)	
	Red y		-		-		
	Green x		-		-		
	Green y		-		-		
	Blue x		-		-		
	Blue y		-		-		
	White x		-		-		
	White y		-		-		

Note (1) Measurement Setup: The LCD module should be stabilized at given temp. 25°C for 15 minutes to avoid abrupt temperature change during measuring. In order to stabilize the luminance, the measurement should be executed after lighting backlight for 15 minutes in a windless room.

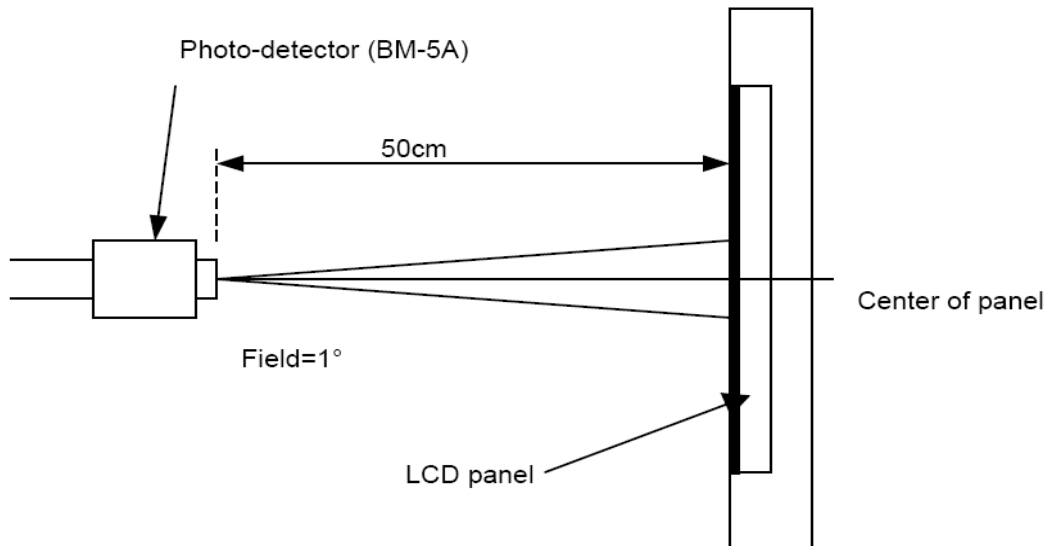

Note (2) Definition of Viewing Angle

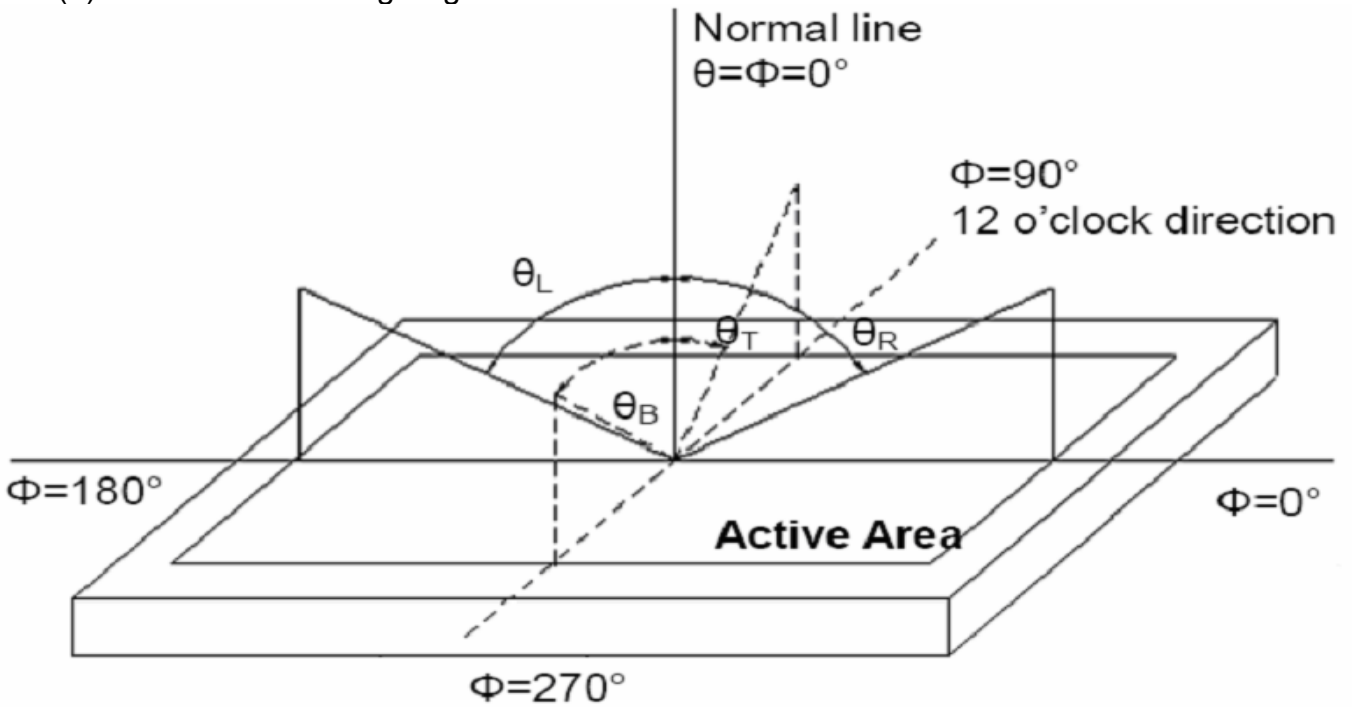

Note (3) Definition of Contrast Ratio (CR)

The contrast ratio can be calculated by the following expression

$$\text{Contrast Ratio (CR)} = L_{63} / L_0$$

L63: Luminance of gray level 63, L0: Luminance of gray level 0

Note (4) Definition of response time

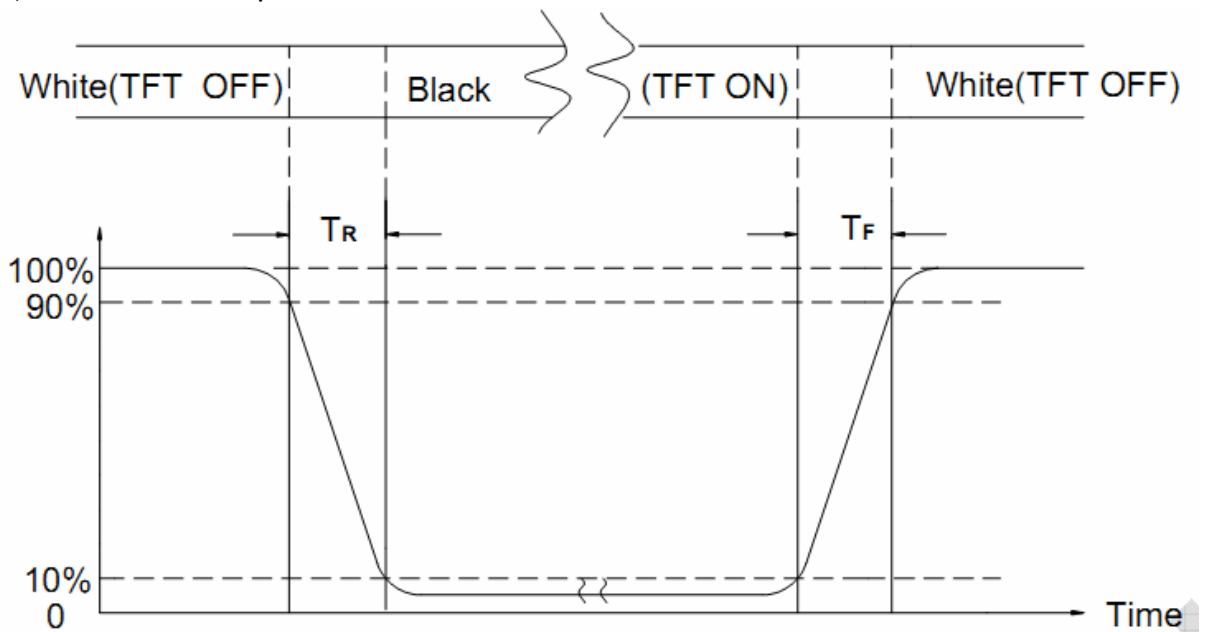

Note (5) Definition of Transmittance (Module is without signal input)

$$\text{Transmittance} = \text{Center Luminance of LCD} / \text{Center Luminance of Back Light} \times 100\%$$

Note (6) Definition of color chromaticity (CIE1931)

Color coordinates measured at the center point of LCD

10. Reliability Test Conditions and Methods

NO.	TEST ITEMS	TEST CONDITION											
①	High Temperature Storage	Keep in 80°C ±5°C 240 hrs Surrounding temperature, then storage at normal condition 4hrs.											
②	Low Temperature Storage	Keep in -30°C ±5°C 240 hrs Surrounding temperature, then storage at normal condition 4hrs.											
③	High Temperature / High Humidity Storage Test	Keep in 70 °C / 90% R.H duration for 240 hrs Surrounding temperature, then storage at normal condition 4hrs. (Excluding the polarizer)											
④	Humidity Non-Operating Temperature Shock	<div style="text-align: center;"> $\begin{matrix} -20^{\circ}\text{C} & \rightarrow & 70^{\circ}\text{C} \\ (60\text{mins}) & (5\text{mins}) & (60\text{mins}) \\ \leftarrow & & \rightarrow \\ & 10 \text{ Cycle} & \end{matrix}$ </div> Surrounding temperature, then storage at normal condition 4hrs.											
⑤	ESD Test	Air Discharge: Apply 2 KV with 5 times Discharge for each polarity +/-	Contact Discharge: Apply 250 V with 5 times discharge for each polarity +/-										
		1. Temperature ambience : 15°C ~ 35°C 2. Humidity relative : 30% ~ 60% 3. Energy Storage Capacitance(Cs + Cd) : 150pF±10% 4. Discharge Resistance(Rd) : 330Ω±10% 5. Discharge, mode of operation : Single Discharge (time between successive discharges at least 1 sec) (Tolerance if the output voltage indication : ±5%)											
⑥	Vibration Test (Packaged)	1. Sine wave 10~55 Hz frequency (1 min/sweep) 2. The amplitude of vibration : 1.5 mm 3. Each direction (X、Y、Z) duration for 2 Hrs											
⑦	Drop Test (Packaged)	<table border="1" style="margin-left: auto; margin-right: auto;"> <thead> <tr> <th>Packing Weight (Kg)</th> <th>Drop Height (cm)</th> </tr> </thead> <tbody> <tr> <td>0 ~ 45.4</td> <td>122</td> </tr> <tr> <td>45.4 ~ 90.8</td> <td>76</td> </tr> <tr> <td>90.8 ~ 454</td> <td>61</td> </tr> <tr> <td>Over 454</td> <td>46</td> </tr> </tbody> </table>		Packing Weight (Kg)	Drop Height (cm)	0 ~ 45.4	122	45.4 ~ 90.8	76	90.8 ~ 454	61	Over 454	46
		Packing Weight (Kg)	Drop Height (cm)										
0 ~ 45.4	122												
45.4 ~ 90.8	76												
90.8 ~ 454	61												
Over 454	46												
Drop Direction : ※ 1 corner / 3 edges / 6 sides each 1time													

11. Inspection Standard

11.1. QUALITY :

THE QUALITY OF GOODS SUPPLIED TO PURCHASER SHALL COME UP TO THE FOLLOWING STANDARD.

11.1.1. INSPECTION TOOLS AND INSTRUMENTS

Vernier calipers, film scales, multimeter, magnifying eyepiece, ND5%, luminance meter and so on.

11.1.2. THE METHOD OF PRESERVING GOODS

AFTER DELIVERY OF GOODS FROM YUXIANG TO PURCHASER. PURCHASER SHALL CONTROL THE LCM AT -10 TO 40 ,AND IT MIGHT BE DESIRABLE TO KEEP AT THE NORMAL ROOM TEMPERATURE AND HUMIDITY UNTIL INCOMING INSPECTION OR THROWING INTO PROCESS LINE.

11.1.3. INCOMING INSPECTION

(A) THE METHOD OF INSPECTION

IF PURCHASER MAKE AN INCOMING INSPECTION , A SAMPLING PLAN SHALL BE APPLIED ON THE CONDITION THAT QUALITY OF ONE DELIVERY SHALL BE REGARDED AS ONE LOT.

(B) THE STANDARD OF QUALITY

ISO-2859-1 (SAME AS MIL-STD-105E) ,LEVEL:II

CLASS	AQL(%)
CRITICAL	0.4 %
MAJOR	0.65 %
MINOR	1.5 %

EVERY ITEM SHALL BE INSPECTED ACCORDING TO THE CLASS.

(C) MEASURE

IF AS THE RESULT OF ABOVE RECEIVING INSPECTION , A LOT OUT IS DISCOVERED. PURCHASER SHALL BE INFORM SELLER OF IT WITHIN SEVEN DAYS. BUT FIRST SHIPMENT WITHIN FOURTEEN DAYS.

11.1.4. WARRANTY POLICY

YUXIANG WILL PROVIDE ONE-YEAR WARRANTY FOR THE PRODUCTS ONLY IF UNDER SPECIFICATION OPERATING CONDITIONS. YUXIANG WILL REPLACE NEW PRODUCTS FOR THESE DEFECT PRODUCTS WHICH UNDER WARRANTY PERIOD AND BELONG TO THE RESPONSIBILITY OF YUXIANG.

11.2. CHECKING CONDITION

11.2.1.CHECKING DIRECTION SHALL BE IN THE 45 DEGREE AREA TO FACE THE SAMPLE.

11.2.2.CHECKER SHALL SEE OVER 300±25 mm. WITH BARE EYES FAR FROM SAMPLE

11.2.3.Ambient Illumination:

0 ~30 Lux for functional inspection

500 ~ 1200 Lux for external appearance inspection.

11.2.4. TEST AREA:

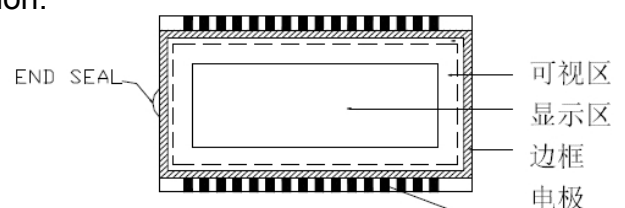
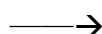

11.2.5. Inspection should be carried out with rope electrostatic ring and static finger cover (both hands except small fingers must be worn)

11.2.6. The inspector may make a visual inspection or a comparative examination with a film

ruler and a magnifying eyepiece. Individual defects shall be determined according to the limited samples.

11.2.7. Functional testing uses electrical testing fixtures or test fixtures required by customers.

11.2.8. the ion fan should be used when testing.

11.2.9. the principle of judgment

11.2.10 If the defect outside the visual area does not affect the assembly and display, it will be judged as a good product.

11.2.11 Poor definition

Pixel:

A combination of three sub-pixels (Red + Green + Blue).



Dot:

Any of the sub-pixels (Red or Green or Blue).

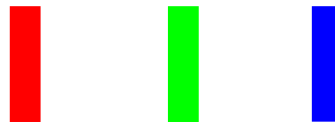

Bright and dark dots:

A point pixel (sub-pixel: R, G, B pixels) is lit or turned off during the display function test.

Highlights:

Usually considered to be shown on a black screen.

Dark spots:

They are generally considered to be shown on R, G, B solid colors or white images.

Neighborhood:

Two or three adjacent point pixels (dot: sub-pixel) connected together (R, G or G, B or B, R or RGB).

11.3. INSPECTION PLAN :

CLASS	ITEM	JUDGEMENT	CLASS
PACKING & INDICATE	1. OUTSIDE AND INSIDE PACKAGE	"MODEL NO." , "LOT NO." AND "QUANTITY" SHOULD INDICATE ON THE PACKAGE.	Minor
	2. MODEL MIXED AND QUANTITY	OTHER MODEL MIXED.....REJECTED QUANTITY SHORT OR OVER.....REJECTED	Critical
	3. PRODUCT INDICATION	"MODEL NO." SHOULD INDICATE ON THE PRODUCT	Major
ASSEMBLY	4. DIMENSION, LCD GLASS SCRATCH AND SCRIBE DEFECT.	ACCORDING TO SPECIFICATION OR DRAWING.	Major
APPEARANCE	5. VIEWING AREA	POLARIZER EDGE OR LCD'S SEALING LINE IS VISABLE IN THE VIEWING AREAREJECTED	Minor
	6. BLEMISH · BLACK SPOT · WHITE SPOT IN THE LCD AND LCD GLASS CRACKS	ACCORDING TO STANDARD OF VISUAL INSPECTION(INSIDE VIEWING AREA)	Minor
	7. BLEMISH · BLACK SPOT WHITE SPOT AND SCRATCH ON THE POLARIZER	ACCORDING TO STANDARD OF VISUAL INSPECTION(INSIDE VIEWING AREA)	Minor
	8. BUBBLE IN POLARIZER	ACCORDING TO STANDARD OF VISUAL INSPECTION(INSIDE VIEWING AREA)	Minor
	9. LCD'S RAINBOW COLOR	STRONG DEVIATION COLOR (OR NEWTON RING) OF LCD.....REJECTED. OR ACCORDING TO LIMITED SAMPLE (IF NEEDED, AND INSIDE VIEWING AREA)	Minor
ELECTRICAL	10. ELECTRICAL AND OPTICAL CHARACTERISTICS (CONTRAST· VOP · CHROMATICITY ... ETC)	ACCORDING TO SPECIFICATION OR DRAWING . (INSIDE VIEWING AREA)	Critical
	11.MISSING LINE	MISSING DOT · LINE · CHARACTERREJECTED	Critical
	12.SHORT CIRCUIT· WRONG PATTERN DISPLAY	NO DISPLAY · WRONG PATTERN DISPLAY · CURRENT CONSUMPTION OUT OF SPECIFICATION..... REJECTED	Critical
	13. DOT DEFECT (FOR COLOR AND TFT)	ACCORDING TO STANDARD OF VISUAL INSPECTION	Minor

11.4. STANDARD OF VISUAL INSPECTION

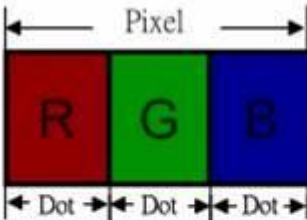
NO.	CLASS	ITEM	JUDGEMENT																				
11.4.1	MINOR	BLACK AND WHITE SPOT FOREIGN MATERIEL DUST IN THE CELL BLEMISH SCRATCH	<p>(A) ROUND TYPE: unit : mm.</p> <table border="1"> <thead> <tr> <th>DIAMETER (mm.)</th> <th>ACCEPTABLE Q'TY</th> </tr> </thead> <tbody> <tr> <td>$\Phi \leq 0.15$</td> <td>Distance>1mm</td> </tr> <tr> <td>$0.15 < \Phi \leq 0.4$</td> <td>3 (Distance>15mm)</td> </tr> <tr> <td>$0.4 < \Phi$</td> <td>0</td> </tr> </tbody> </table> <p>NOTE: $\Phi=(\text{LENGTH}+\text{WIDTH})/2$</p> <p>(B) LINEAR TYPE: unit : mm.</p> <table border="1"> <thead> <tr> <th>LENGTH</th> <th>WIDTH</th> <th>ACCEPTABLE Q'TY</th> </tr> </thead> <tbody> <tr> <td>-----</td> <td>$W \leq 0.03$</td> <td>Distance>1mm</td> </tr> <tr> <td>$L \leq 4.0$</td> <td>$0.03 < W \leq 0.05$</td> <td>3 (Distance>15mm)</td> </tr> <tr> <td>-----</td> <td>$0.05 < W$</td> <td>FOLLOW ROUND TYPE</td> </tr> </tbody> </table>	DIAMETER (mm.)	ACCEPTABLE Q'TY	$\Phi \leq 0.15$	Distance>1mm	$0.15 < \Phi \leq 0.4$	3 (Distance>15mm)	$0.4 < \Phi$	0	LENGTH	WIDTH	ACCEPTABLE Q'TY	-----	$W \leq 0.03$	Distance>1mm	$L \leq 4.0$	$0.03 < W \leq 0.05$	3 (Distance>15mm)	-----	$0.05 < W$	FOLLOW ROUND TYPE
DIAMETER (mm.)	ACCEPTABLE Q'TY																						
$\Phi \leq 0.15$	Distance>1mm																						
$0.15 < \Phi \leq 0.4$	3 (Distance>15mm)																						
$0.4 < \Phi$	0																						
LENGTH	WIDTH	ACCEPTABLE Q'TY																					
-----	$W \leq 0.03$	Distance>1mm																					
$L \leq 4.0$	$0.03 < W \leq 0.05$	3 (Distance>15mm)																					
-----	$0.05 < W$	FOLLOW ROUND TYPE																					
11.4.2	MINOR	BUBBLE IN POLARIZER DENT ON POLARIZER	<p style="text-align: right;">unit : mm.</p> <table border="1"> <thead> <tr> <th>DIAMETER</th> <th>ACCEPTABLE Q'TY</th> </tr> </thead> <tbody> <tr> <td>$\Phi \leq 0.2$</td> <td>Distance>1mm</td> </tr> <tr> <td>$0.2 < \Phi \leq 0.5$</td> <td>3 (Distance>15mm)</td> </tr> <tr> <td>$0.5 < \Phi$</td> <td>0</td> </tr> </tbody> </table>	DIAMETER	ACCEPTABLE Q'TY	$\Phi \leq 0.2$	Distance>1mm	$0.2 < \Phi \leq 0.5$	3 (Distance>15mm)	$0.5 < \Phi$	0												
DIAMETER	ACCEPTABLE Q'TY																						
$\Phi \leq 0.2$	Distance>1mm																						
$0.2 < \Phi \leq 0.5$	3 (Distance>15mm)																						
$0.5 < \Phi$	0																						
11.4.3	MINOR	Dot Defect	<table border="1"> <thead> <tr> <th>Items</th> <th>ACC. Q'TY</th> </tr> </thead> <tbody> <tr> <td>Bright dot</td> <td>$N \leq 2$ (Distance>15mm)</td> </tr> <tr> <td>Dark dot</td> <td>$N \leq 3$ (Distance>15mm)</td> </tr> </tbody> </table> <p>Pixel Define :</p>  <p>Note 1: The definition of dot: The size of a defective dot over 1/2 of whole dot is regarded as one defective dot. Definition:<1/2dot and visible by 5% ND filter $N \leq 5$</p> <p>Note 2: Bright dot: Dots appear bright and unchanged in size in which LCD panel is displaying under black pattern.</p> <p>Note 3: Dark dot: Dots appear dark and unchanged in size in which LCD panel is displaying under pure red, green, blue pattern.</p>	Items	ACC. Q'TY	Bright dot	$N \leq 2$ (Distance>15mm)	Dark dot	$N \leq 3$ (Distance>15mm)														
Items	ACC. Q'TY																						
Bright dot	$N \leq 2$ (Distance>15mm)																						
Dark dot	$N \leq 3$ (Distance>15mm)																						
11.4.4	MINOR	Mura	Not visible through 5% ND filter in 50% gray or judge by limit sample if necessary																				

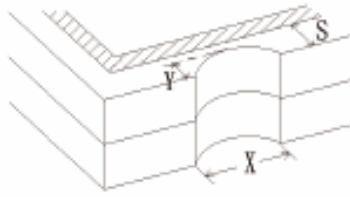
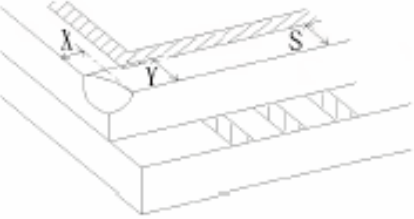
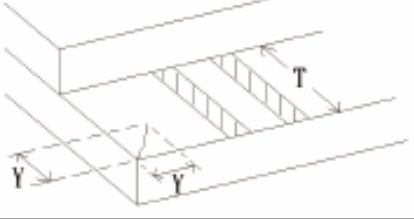
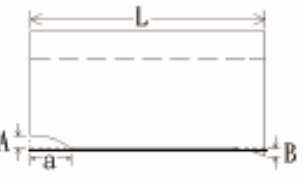
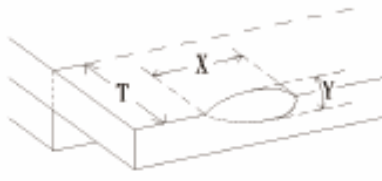
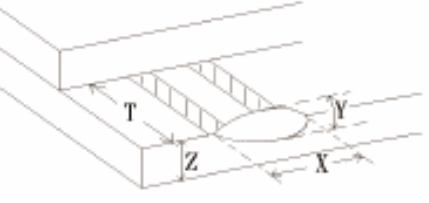
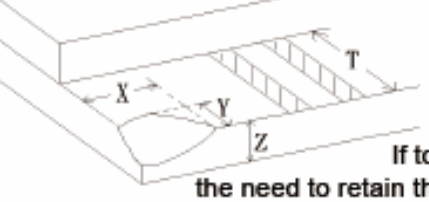
NO.	CLASS	ITEM	JUDGEMENT
11.4.5	MINOR	LCD GLASS CHIPPING	 <p>$X \geq 3\text{mm}$ $Y > S$</p> <p>Reject</p>
11.4.6	MINOR	LCD GLASS CHIPPING	 <p>$X \text{ or } Y > S$</p> <p>Reject</p>
11.4.7	MAJOR	LCD GLASS GLASS CRACK	 <p>Continuous burst NG</p> <p>Reject</p>
11.4.8	MAJOR	LCD GLASS SCRIBE DEFECT	 <p>ACCORDING TO DIMENSION</p>
11.4.9	MINOR	LCD GLASS CHIPPING (ON THE TERMINAL AREA)	 <p>$Y < 1/2Z$ $Y \geq 0.5\text{mm}$ $X \geq 3\text{mm}$</p> <p>Reject</p>
11.4.10	MINOR	LCD GLASS CHIPPING (ON THE TERMINAL SURFACE)	 <p>$Y < 1/2Z$ $Y \geq 0.5\text{mm}$ $X \geq 3\text{mm}$</p> <p>Reject</p>
11.4.11	MINOR	LCD GLASS CHIPPING	 <p>$X \geq 3\text{mm}$ $Y \geq T$</p> <p>Reject</p> <p>If touch the electrode lines, the need to retain the two-thirds electrode lines</p>

12. Handling Precautions

12.1 Mounting method

The LCD panel of YUXIANG TFT module consists of two thin glass plates with polarizers which easily be damaged. And since the module is so constructed as to be fixed by utilizing fitting holes in the printed circuit board.

Extreme care should be needed when handling the LCD modules.

12.2 Caution of LCD handling and cleaning

When cleaning the display surface, Use soft cloth with solvent [Recommended below] and wipe lightly

- Isopropyl alcohol
- Ethyl alcohol

Do not wipe the display surface with dry or hard materials that will damage the polarizer surface.

Do not use the following solvent:

- Water
- Aromatics

Do not wipe ITO pad area with the dry or hard materials that will damage the ITO patterns

Do not use the following solvent on the pad or prevent it from being contaminated:

- Soldering flux
- Chlorine (Cl) , Sulfur (S)

If goods were sent without being silicon coated on the pad, ITO patterns could be damaged due to the corrosion as time goes on.

If ITO corrosion happens by miss-handling or using some materials such as Chlorine (Cl), Sulfur (S) from customer, Responsibility is on customer.

12.3 Caution against static charge

The LCD module uses C-MOS LSI drivers, so we recommend that you:

Connect any unused input terminal to POWER or GROUND, do not input any signals before power is turned on, and ground your body, work/assembly areas, and assembly equipment to protect against static electricity.

12.4 packing

- Module employs LCD elements and must be treated as such.
- Avoid intense shock and falls from a height.
- To prevent modules from degradation, do not operate or store them exposed direct to sunshine or high temperature/humidity

12.5 Caution for operation

- It is an indispensable condition to drive LCD's within the specified voltage limit since the higher voltage than the limit causes the shorter LCD life.
- An electrochemical reaction due to direct current causes LCD's undesirable deterioration, so that the use of direct current drive should be avoided.
- Response time will be extremely delayed at lower temperature than the operating temperature range and on the other hand at higher temperature LCD's show dark color in them. However those phenomena do not mean malfunction or out of order with LCD's, which will come back in the specified operation temperature.
- If the display area is pushed hard during operation, some font will be abnormally displayed but it resumes normal condition after turning off once.
- Slight dew depositing on terminals is a cause for electro-chemical reaction resulting in terminal open circuit.

Usage under the maximum operating temperature, 50%Rh or less is required.

12.6 storing

In the case of storing for a long period of time for instance, for years for the purpose or replacement use, the following ways are recommended.

- Storage in a polyethylene bag with the opening sealed so as not to enter fresh air outside in it. And with no desiccant.
- Placing in a dark place where neither exposure to direct sunlight nor light's keeping the storage temperature range.
- Storing with no touch on polarizer surface by the anything else.
[It is recommended to store them as they have been contained in the inner container at the time of delivery from us

12.7 Safety

- It is recommendable to crash damaged or unnecessary LCD's into pieces and wash off liquid crystal by either of solvents such as acetone and ethanol, which should be burned up later.
- When any liquid leaked out of a damaged glass cell comes in contact with your hands, please wash it off well with soap and water

13. Precaution for Use

13.1

A limit sample should be provided by the both parties on an occasion when the both parties agreed its necessity. Judgment by a limit sample shall take effect after the limit sample has been established and confirmed by the both parties.

13.2

On the following occasions, the handing of problem should be decided through discussion and agreement between responsible of the both parties.

- When a question is arisen in this specification
- When a new problem is arisen which is not specified in this specifications
- When an inspection specifications change or operating condition change in customer is reported to YUXIANG TFT , and some problem is arisen in this specification due to the change
- When a new problem is arisen at the customer's operating set for sample evaluation in the customer site.

14. Packing Method

TBD